



KITCHEN EQUIPMENT



Guangzhou Jiahua Catering Equipment Co.,Ltd.

Add:No.F2-041,2nd floor,bo huang international hotel supplies purchasing center,zone A,xiahua road,baiyun district,guangzhou,China

Tel:8620-31922794
FAX:8620-31922794
Mobile:86-13533886238/13342865157/13631022403
Contact:Dervin Fang
Email:dervin@jhhotelsupplies.com
Web:www.jhhotelsupplies.com



Buffet stove series

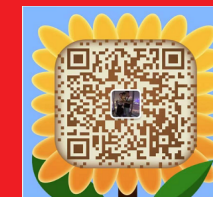

Guangzhou Jiahua Catering Equipment Co.,Ltd.



TABLE OF CONTENTS 目录

● ABOUT US

NEW PRODUCT 2021 2021 年新品	03
J SERIES J 系列	07
AUTOMATIC ELECTRIC NOODLE BOILER 自动煮面机	17
MULTIPURPOSE ELECTRIC GRIDDLE 多用途煎炉	17
COOKING MACHINE SERIES 烹饪机系列	19
VACUUM PACKAGING MACHINE SERIES 真空包装机系列	20

● CHAFING DISH

COLD-HOT CHAFING DISH 冷热可切换餐炉	23
TC-S SERIES 调温 TC-S 系列	25
TC-B SERIES 调温 TC-B 系列	31
M SERIES 触动 M 系列	34
H SERIES 触动 H 系列	39
MD SERIES 触动 MD 系列	43
S SERIES 可视 S 系列	44
B SERIES 传统 B 系列	49
2 SERIES 传统 2 系列	53
C SERIES 小型 C 系列	57
BUTTERFLY SERIES 碟菲系列	77
ACCESSORIES SERIES 配件系列	81

● OTHER SERIES

STEAM SERIES 蒸笼系列	93
WINE FOUNTAIN SERIES 红酒喷泉系列	95
BUFFET STAND SERIES 海鲜塔系列	95
CHOCOLATE FOUNTAIN SERIES 巧克力喷泉系列	97
SERVICE WAGON AND CEREAL DISPENSER SERIES 餐车 / 麦片机系列	99
JUICE DISPENSER SERIES 果汁机系列	101
COFFEE URNS SERIES 咖啡鼎系列	109
INDUCTION COOKER SERIES 电磁炉系列	111
GLASS INSULATION MACHINE SERIES 保温台系列	113
SERVICE TRAYS AND STAND SERIES 镜盘镜台系列	115
ACCESSORIES SERIES 用品系列	117
BUFFET DISPLAY SERIES 摆件系列	121
HEATING LAMP SERIES 保温灯系列	136
PROOFER WARMER SERIES 保温柜系列	138
DISHES 暖碟机	139
ANTI-JAMMING GN PANS 不锈钢份数盘	141

2021 NEW PRODUCTS

2021 新品

E20101

碟菲餐炉

- > Round 38cm Chafer / Glass Lid
- > Electrical

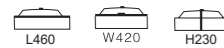

型号	容量	额定功率	额定电压	额定频率	
E20101	6L	500W	220-240V~	50/60HZ	配 DB-230 适用 10A 国际插头

TCE20101

温控显示碟菲炉

- > 38cm Round Electrical Chafer
- > Glass Lid
- > Temperature Control



型号	容量	额定功率	额定电压	额定频率	
TCE20101	6L	500W	220-240V~	50/60HZ	配 DB-230 适用 10A 国际插头

21301 / 21305

圆形餐炉 / 大玻璃盖

- > Round 38cm / 30cm full area glass vision Lid / induction Chafing dish
- > ss insert



21301



21305



E20102

碟菲餐炉

- > 2/3 GN Chafer
- > Glass Lid
- > Electrical



型号	容量	额定功率	额定电压	额定频率	
E20102	5.1L	500W	220-240V~	50/60HZ	配 DB-230 适用 10A 国际插头

TCE20102

温控显示碟菲炉

- > Electrical 2/3 GN Chafer
- > Glass Lid
- > Temperature Control



型号	容量	额定功率	额定电压	额定频率	
TCE20102	5.1L	500W	220-240V~	50/60HZ	配 DB-230 适用 10A 国际插头

21302 / 21306

方形餐炉 / 大玻璃盖

- > Square GN2/3 / GN 1/2 full area glass vision Lid / induction Chafing dish
- > ss insert



21302



21306



E20104

碟菲餐炉

- > 1/1 GN Chafer
- > Glass / Steel Lid
- > Electrical

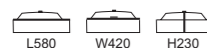

型号	容量	额定功率	额定电压	额定频率	
E20104	单 7.6L 双 3.4L*2	500W	220-240V~	50/60HZ	配 DB-230 适用 10A 国际插头

TCE20104

温控显示碟菲炉

- > Electrical 1/1 GN Chafer
- > Glass Lid
- > Temperature Control



型号	容量	额定功率	额定电压	额定频率	
TCE20104	单 7.6L 双 3.4L*2	500W	220-240V~	50/60HZ	配 DB-230 适用 10A 国际插头

21304

长方形餐炉 / 大玻璃盖

- > Rectangle GN1/1 full area glass vision Lid / induction Chafing dish
- > ss insert



NEW CHINESE RED 全新中国红

HIGH-TECH MATERIALS 高科技材料

Special show window, use the Dupont's hightec material. Original creation making craft, no steam and greasy stain.

采用杜邦公司高科技材料，独创制作工艺，可视窗防雾化，防油腻。

BAKING VANISH TECHNOLOGY 高温烤漆技术

Using Advanced High Temperature Painting Technology, Can withstand the test of 200 degrees Celsius

采用先进的高温烤漆技术，经得住 200 摄氏度的高温考验。

HS SERIES (系列)

HS301

中国红圆形餐炉 / 玻璃盖

- > Round 38cm Glass Lid Vision
- Induction Chafing dish
- > w/ss insert
- > 6L



HS301G

中国红圆形餐炉 / 钢盖

- > Round 38cm Steel Lid Vision
- Induction Chafing dish
- > w/ss insert
- > 6L



HS302

中国红方形餐炉 / 玻璃盖

- > Square GN2/3 Glass Lid Vision
- Induction Chafing dish
- > w/ss insert
- > 5.1L



HS302G

中国红方形餐炉 / 钢盖

- > Square GN2/3 Steel Lid Vision
- Induction Chafing dish
- > w/ss insert
- > 5.1L



HS304

中国红长方形餐炉 / 玻璃盖

- > Oblong GN1/1 Glass Lid Vision
- Red color Chafing dish
- > w/ss insert
- > 8.3L



HS304G

中国红长形餐炉 / 钢盖

- > Oblong GN1/1 Steel Lid Vision
- Induction Chafing dish
- > w/ss insert
- > 8.3L



J SERIES (系列)

标配酒精炉可选配电热板

J801

圆形餐炉 / 玻璃盖

> Round 38cm Glass Lid Vision
induction Chafing Dish
> w/ss insert



J801G

圆形餐炉 / 钢盖

> Round 38cm Steel Lid Vision
induction Chafing Dish
> w/ss insert



型号	容量	额定功率	额定电压	额定频率	
J801	6L	500W	220-240V~	50/60HZ	配 DB-500
J801G	6L	500W	220-240V~	50/60HZ	适用 10A 国际插头

J802

方形餐炉 / 玻璃盖

> Square GN2/3 Glass Lid Vision
induction Chafing Dish W
> w/ss insert



J802G

方形餐炉 / 钢盖

> Square GN2/3 Steel Lid Vision
induction Chafing Dish W
> w/ss insert



型号	容量	额定功率	额定电压	额定频率	
J802	5.1L	500W	220-240V~	50/60HZ	配 DB-500
J802G	5.1L	500W	220-240V~	50/60HZ	适用 10A 国际插头

J803

圆形汤炉 / 玻璃盖

> Round Glass Lid
induction Soup station
> w/ss insert



J803G

圆形汤炉 / 钢盖

> Round Steel Lid
induction Soup station
> w/ss insert



型号	容量	额定功率	额定电压	额定频率	
J803	12L	350W	220-240V~	50/60HZ	配 DB-350RJ
J803G	12L	350W	220-240V~	50/60HZ	适用 10A 国际插头

J804

长方形餐炉 / 玻璃盖

> Oblong GN1/1 Glass Lid Vision
induction Chafing Dish
> w/ss insert



J804G

长方形餐炉 / 钢盖

> Oblong GN1/1 Steel Lid Vision
induction Chafing Dish
> w/ss insert



型号	容量	额定功率	额定电压	额定频率	
J804	8.3L	500W	220-240V~	50/60HZ	配 DB-500
J804G	8.3L	500W	220-240V~	50/60HZ	适用 10A 国际插头

J SERIES (系列)

标配酒精炉可选配电热板

J805

圆形餐炉 / 玻璃盖

> Round 30cm Glass Lid Vision
induction Chafing Dish
> w/ss insert



J805G

圆形餐炉 / 钢盖

> Round 30cm Steel Lid Vision
induction Chafing Dish
> w/ss insert



型号	容量	额定功率	额定电压	额定频率	
J805	3.8L	350W	220-240V~	50/60HZ	配 DB-350
J805G	3.8L	350W	220-240V~	50/60HZ	适用 10A 国际插头

J806

方形餐炉 / 玻璃盖

> Square GN1/2 Glass Lid Vision
induction Chafing Dish
> w/ss insert

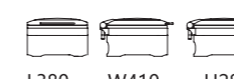

J806G

方形餐炉 / 钢盖

> Square GN1/2 Steel Lid Vision
induction Chafing Dish
> w/ss insert



型号	容量	额定功率	额定电压	额定频率	
J806	3.8L	350W	220-240V~	50/60HZ	配 DB-350
J806G	3.8L	350W	220-240V~	50/60HZ	适用 10A 国际插头

J901

圆形餐炉 / 玻璃盖

> Round 38cm Glass Lid Vision
induction Chafing Dish
> w/ss insert with electric heater



J901G

圆形餐炉 / 钢盖

> Round 38cm Steel Lid Vision
induction Chafing Dish
> w/ss insert with electric heater

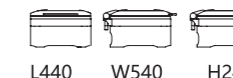

型号	容量	额定功率	额定电压	额定频率	
J901	6L	500W	220-240V~	50/60HZ	配 DB-500
J901G	6L	500W	220-240V~	50/60HZ	适用 10A 国际插头

J902

方形餐炉 / 玻璃盖

> Square GN2/3 Glass Lid Vision
induction Chafing Dish
> w/ss insert with electric heater



J902G

方形餐炉 / 钢盖

> Square GN2/3 Steel Lid Vision
induction Chafing Dish
> w/ss insert with electric heater

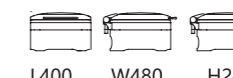

型号	容量	额定功率	额定电压	额定频率	
J902	5.1L	500W	220-240V~	50/60HZ	配 DB-500
J902G	5.1L	500W	220-240V~	50/60HZ	适用 10A 国际插头

J SERIES (系列)

仅适用电热板

J903

圆形汤炉 / 玻璃盖

- > Round Glass Lid induction Soup station
- > w/ss insert with electric heater



J903G

圆形汤炉 / 钢盖

- > Round Steel Lid induction Soup station
- > w/ss insert with electric heater



型号	容量	额定功率	额定电压	额定频率	
J903	12L	350W	220-240V~	50/60HZ	配 DB-350RJ
J903G	12L	350W	220-240V~	50/60HZ	适用 10A 国际插头

J904

长方形餐炉 / 玻璃盖

- > Oblong GN1/1 Glass Lid Vision induction Chafing Dish
- > w/ss insert with electric heater



J904G

长方形餐炉 / 钢盖

- > Oblong GN1/1 Steel Lid Vision induction Chafing Dish
- > w/ss insert with electric heater



型号	容量	额定功率	额定电压	额定频率	
J904	8.3L	500W	220-240V~	50/60HZ	配 DB-500
J904G	8.3L	500W	220-240V~	50/60HZ	适用 10A 国际插头

J905

圆形餐炉 / 玻璃盖

- > Round 30cm Glass Lid Vision induction Chafing Dish
- > w/ss insert with electric heater



J905G

圆形餐炉 / 钢盖

- > Round 30cm Steel Lid Vision induction Chafing Dish
- > w/ss insert with electric heater



型号	容量	额定功率	额定电压	额定频率	
J905	3.8L	350W	220-240V~	50/60HZ	配 DB-350
J905G	3.8L	350W	220-240V~	50/60HZ	适用 10A 国际插头

J906

方正餐炉 / 玻璃盖

- > Square GN1/2 Glass Lid Vision induction Chafing Dish
- > w/ss insert with electric heater



J906G

方正餐炉 / 钢盖

- > Square GN1/2 Steel Lid Vision induction Chafing Dish
- > w/ss insert with electric heater



型号	容量	额定功率	额定电压	额定频率	
J906	3.8L	350W	220-240V~	50/60HZ	配 DB-350RJ
J906G	3.8L	350W	220-240V~	50/60HZ	适用 10A 国际插头

J SERIES (系列)

仅适用电热板

J1001

圆形餐炉 / 玻璃盖

- > Round 38cm Glass Lid Vision induction Chafing Dish
- > w/ss insert with electric heater



J1001G

圆形餐炉 / 钢盖

- > Round 38 cm Steel Lid Vision induction Chafing Dish
- > w/ss insert with electric heater



型号	容量	额定功率	额定电压	额定频率	
J1001	6L	500W	220-240V~	50/60HZ	配 DB-500
J1001G	6L	500W	220-240V~	50/60HZ	适用 10A 国际插头

J1002

方形餐炉 / 玻璃盖

- > Square GN2/3 Glass Lid Vision induction Chafing Dish
- > w/ss insert with electric heater



J1002G

方形餐炉 / 钢盖

- > Square GN2/3 Steel Lid Vision induction Chafing Dish
- > w/ss insert with electric heater



型号	容量	额定功率	额定电压	额定频率	
J1002	5.1L	500W	220-240V~	50/60HZ	配 DB-500
J1002G	5.1L	500W	220-240V~	50/60HZ	适用 10A 国际插头

J1003

圆形汤炉 / 玻璃盖

- > Round Glass Lid induction Soup Station
- > w/ss insert with electric heater



J1003G

圆形汤炉 / 钢盖

- > Square Steel Lid Vision induction soup station
- > ss insert with electric heater



型号	容量	额定功率	额定电压	额定频率	
J1003	12L	350W	220-240V~	50/60HZ	配 DB-500
J1003G	12L	350W	220-240V~	50/60HZ	适用 10A 国际插头

J1004

长方形餐炉 / 玻璃盖

- > Oblong GN1/1 Glass Lid Vision induction Chafing Dish
- > w/ss insert with electric heater



J1004G

长方形餐炉 / 钢盖

- > Oblong GN1/1 Steel Lid Vision induction Chafing Dish
- > w/ss insert with electric heater



型号	容量	额定功率	额定电压	额定频率	
J1004	8.3L	500W	220-240V~	50/60HZ	配 DB-500
J1004G	8.3L	500W	220-240V~	50/60HZ	适用 10A 国际插头

J/C SERIES (系列)

仅适用电热板

J1005

电热碟菲餐炉

> Round 30cm Glass Lid Vision
induction Chafing Dish W
> ss insert with electric heater



J1005G

电热碟菲餐炉 (钢盖)

> Round 30cm Steel Lid Vision
induction Chafing Dish
> ss insert with electric heater



型号	容量	额定功率	额定电压	额定频率	
J1005	3.8L	350W	220-240V~	50/60HZ	配 DB-350
J1005G	3.8L	350W	220-240V~	50/60HZ	适用 10A 国际插头

J1006

电热碟菲餐炉

> Square GN1/2 Glass Lid Vision
induction Chafing Dish
> ss insert with electric heater



J1006G

电热碟菲餐炉 (钢盖)

> Square GN1/2 Steel Lid Vision
induction Chafing Dish
> ss insert with electric heater



型号	容量	额定功率	额定电压	额定频率	
J1006	3.8L	350W	220-240V~	50/60HZ	配 DB-350
J1006G	3.8L	350W	220-240V~	50/60HZ	适用 10A 国际插头

C1980G

电热碟菲餐炉

> Stand for Round 38cm Chafing dish



C1990G

电热碟菲餐炉 (钢盖)

> Stand for Square GN1/2
Chafing dish



C19104G

碟菲餐炉底座 (高框)

> Stand for Oblong GN1/1 Chafing dish

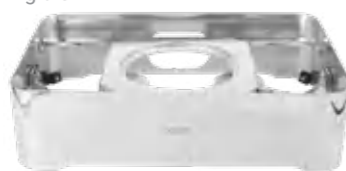

C1970G

碟菲餐炉底座 (高框)

> Stand for Oblong 30cm
Chafing dish



C SERIES (系列)

C19100G

碟菲餐炉底座 (高框)

> Stand for Square GN2/3 Chafing dish



C1980D

碟菲餐炉底座 (低框)

> Stand for Round 38cm Chafing dish

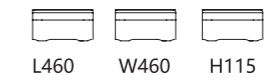

C1990D

碟菲餐炉底座 (低框)

> Stand for Square GN1/2 Chafing dish



C19104D

碟菲餐炉底座 (低框)

> Stand for Oblong GN1/1 Chafing dish

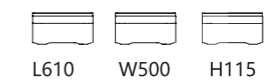

C1970D

碟菲餐炉底座 (低框)

> Stand for Round 30cm
Chafing dish



C19100D

碟菲餐炉底座 (低框)

> Stand for Square GN2/3
Chafing dish



C1980

碟菲餐炉底座

> Stand for Round 38cm Chafing



C1990

碟菲餐炉底座

> Stand for Square GN1/2
Chafing dish



C SERIES (系列)

C19104

碟菲餐炉底座

> Stand for Rectangular GN1/1 Chafing dish



C1970

碟菲餐炉底座

> Stand for Round 30cm Chafing dish



C19100

碟菲餐炉底座

> Stand for Square GN2/3 Chafing dish



复底系列 让您享受到不一样的温度

最新研发 复底餐炉系列
采用 304 不锈钢, 铝材, 不锈钢三种材质的有效组合, 导热更快速, 更均匀。



J19301

多层底圆形餐炉 / 玻璃盖

> Round 38cm Glass Lid Vision induction Chafing dish
> ss insert



J19301G

多层底餐炉 / 钢盖

> Round 38cm Steel Lid Vision induction Chafing dish
> ss insert



J19303

多层底圆形汤炉 / 玻璃盖

> Round Glass Lid Vision Induction Soup Station
> ss insert
> Capacity 12L



J19303G

多层底圆形汤炉 / 钢盖

> Round Glass Lid Vision Induction Soup Station
> ss insert
> Capacity 12L



J SERIES (系列)

电磁炉专用

J19302

多层底方形餐炉 / 玻璃盖

> Square GN2/3 Glass Lid Vision induction Chafing dish
> ss insert



J19302G

多层底方形餐炉 / 钢盖

> Square GN2/3 Steel Lid Vision induction Chafing dish
> ss insert



J19304

多层底长方形餐炉 / 玻璃盖

> Oblong GN1/1 Glass Lid Vision induction Chafing dish
> ss insert



J19304G

多层底长方形餐炉 / 钢盖

> Oblong GN1/1 Steel Lid Vision induction Chafing dish
> ss insert



J19305

多层底圆形餐炉 / 玻璃盖

> Round 30cm Glass Lid Vision induction Chafing dish
> ss insert



J19305G

多层底圆形餐炉 / 钢盖

> Round 30cm Steel Lid Vision induction Chafing dish
> ss insert



J19306

多层底方形餐炉 / 玻璃盖

> Square GN1/2 Glass Lid Vision induction Chafing dish
> ss insert



J19306G

多层底方形餐炉 / 钢盖

> Square GN1/2 Steel Lid Vision induction Chafing dish
> ss insert



CHAFING DISH SERIES (系列)

标配酒精炉可配电热板

2585-6E

长方形简易餐炉

- > Simple rectangular chafing dish
- > stackable



2586-30E

圆形简易餐炉

- > Simple round chafing dish
- > stackable



2586-40E

圆形简易餐炉

- > Simple round chafing dish
- > stackable



型号	容量	额定功率	额定电压	额定频率
2585-6E	8.3L	380W	220-240V~	50/60HZ
2586-30E	4.2L	380W	220-240V~	50/60HZ
2586-40E	7.2L	380W	220-240V~	50/60HZ

适用 DB-380 专用电热板
适用 10A 国际插头



Stylist uses clever conception, change come loose for whole, facilitate receive, save storage space already, do not affect the function of furnace itself and shape again beautiful, collect freely!

设计师采用巧妙的构思，化散为整，便于收纳，既节约储藏空间，又不影响餐炉本身的功能和形状美观，收取自如！

SAUCE CHAFING DISH SERIES (汤汁炉系列)

19001

小餐炉

- > Sauce pot
- > 3.5L

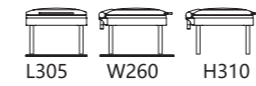

19002

小餐炉

- > Sauce pot
- > 7.5L

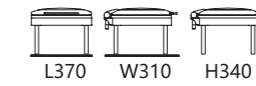

19003-4.5

汤汁炉

- > Sauce Station
- > 4.5L

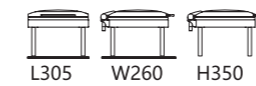

19003-10

汤汁炉

- > Sauce Station
- > 10L

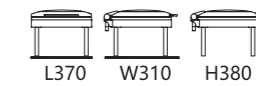

19001-T3.5

汤汁炉

- > Sauce pot
- > 3.5L

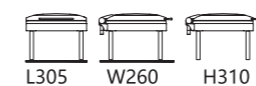

19002-T7.5

汤汁炉

- > Sauce pot
- > 7.5L

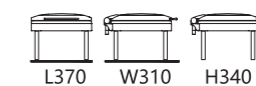

19003-T4.5

汤汁炉

- > Sauce Station
- > 4.5L

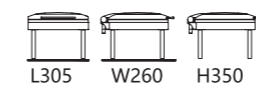

19003-T10

汤汁炉

- > Sauce Station
- > 10L

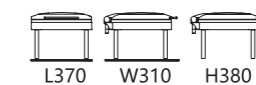

ZM1206

自动煮面机

> Automatic Electric Noodle Boiler with Cabinet

Computer monolithic intelligent core

—More stable performance

304 stainless steel

—Beautiful and durable

New automatic inlet and drain, constant temperature design

—Easy and convenient

Water brake protection system

—More secure

2 sets of 6000W stainless steel electric heating pipe

—Time saving and more efficient

计算机单片智能核心——性能更稳定

304 不锈钢打造——美观更坚固耐用

全新全自动进排水, 恒温设计——轻松更便捷

缺水制动保护系统——安全更放心

2 组 6000W 不锈钢电热管——省时更高效

温度设置范围: 0-100° C

额定电压: 380V

**ZJ1530**

多用途煎炉

> Multipurpose Electric Griddle with Cabinet

High performance automatic thermostat

—safe and stable performance

304 stainless steel

—beautiful and durable

Temperature control knob adjustment

—simple and more accurate

Two sets of heating devices, separate temperature control

—save time, save electricity and more efficient

高性能自动恒温控制器——性能安全更稳定

304 不锈钢打造——美观更坚固耐用

温控旋钮调节——简便更精准

两组加热装置, 单独的温度控制——省时省电更高效

两个炉单独控制

温度设置范围	恒温精度	加热功率	额定电压
0-300° C	±5° C	1500W+3000W	220V

**GW-04**

洗杯机

> Glass Washer

> 340*205*455

额定功率	额定电压	额定频率
400W	220-240V~	50/60HZ

每分钟 1400 转
适用 10A 国际插头

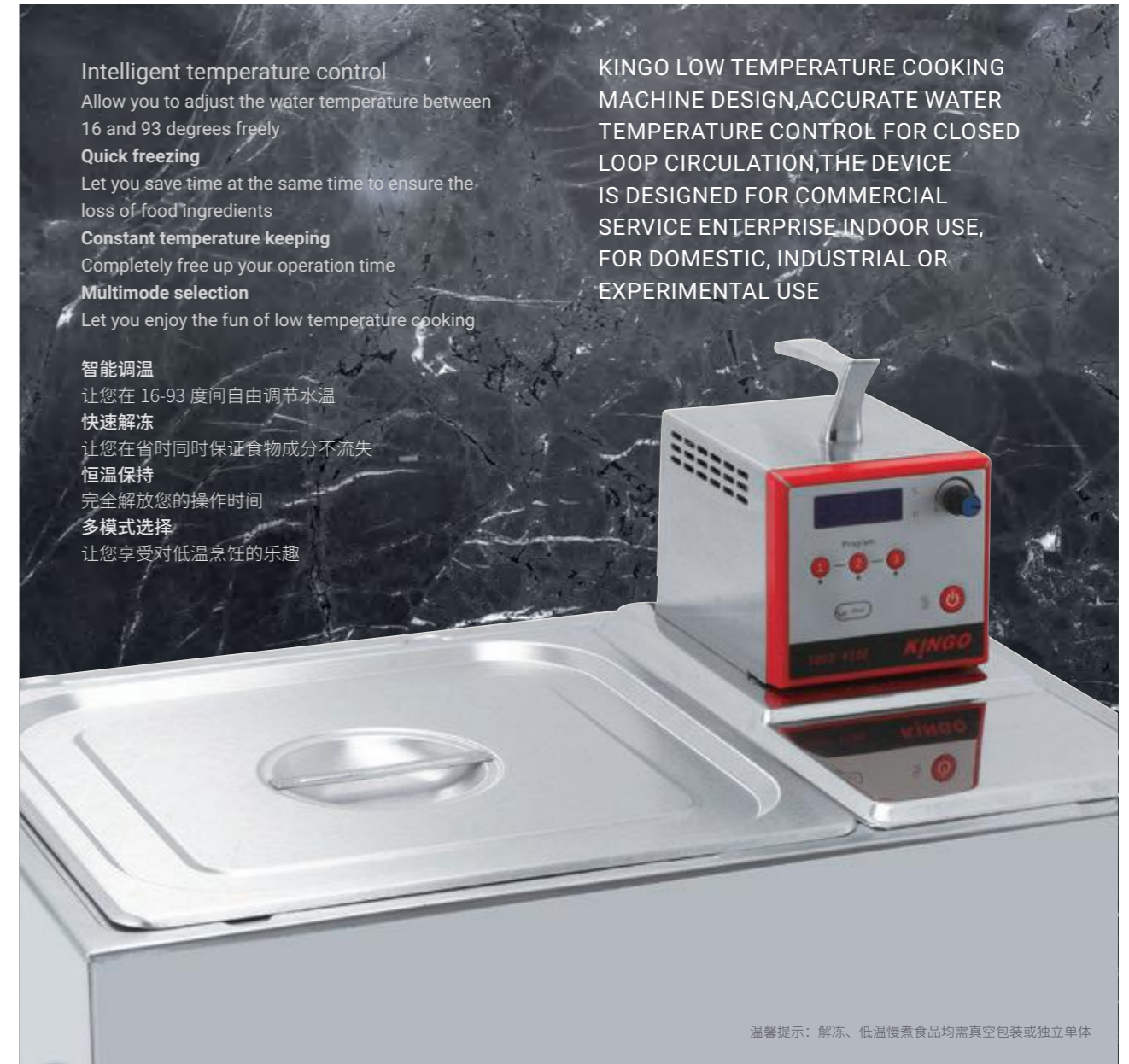
**Intelligent temperature control**

Allow you to adjust the water temperature between 16 and 93 degrees freely

Quick freezing

Let you save time at the same time to ensure the loss of food ingredients

Constant temperature keeping

Completely free up your operation time

Multimode selection

Let you enjoy the fun of low temperature cooking

智能调温

让您在 16-93 度间自由调节水温

快速解冻

让您在省时时同时保证食物成分不流失

恒温保持

完全解放您的操作时间

多模式选择

让您享受对低温烹饪的乐趣

KINGO LOW TEMPERATURE COOKING MACHINE DESIGN, ACCURATE WATER TEMPERATURE CONTROL FOR CLOSED LOOP CIRCULATION, THE DEVICE IS DESIGNED FOR COMMERCIAL SERVICE ENTERPRISE INDOOR USE, FOR DOMESTIC, INDUSTRIAL OR EXPERIMENTAL USE

温馨提示: 解冻、低温慢煮食品均需真空包装或独立单体

SV6088-43

低温烹饪机配 3/4 槽

> Sous Vide-Immersion Circulator, Head, Water basin 3/4 size, and cover

**SV6088-11**

低温烹饪机配 1/1 槽

> Sous Vide-Immersion Circulator, Head, Water basin 1/1 size, and cover



型号	额定功率	额定电压	额定频率
SV6088-43	1200W	220-240V	50/60HZ
SV6088-11	1200W	220-240V	50/60HZ

适用 10A 国际插头
适用 10A 国际插头

KINGO LOW TEMPERATURE COOKING MACHINE DESIGN, ACCURATE WATER TEMPERATURE CONTROL FOR CLOSED LOOP CIRCULATION, THE DEVICE IS DESIGNED FOR COMMERCIAL SERVICE ENTERPRISE INDOOR USE, FOR DOMESTIC, INDUSTRIAL OR EXPERIMENTAL USE

Intelligent temperature control

Allow you to adjust the water temperature between 16 and 93 degrees freely

Quick freezing

Let you save time at the same time to ensure the loss of food ingredients

Constant temperature keeping

Completely free up your operation time

Multimode selection

Let you enjoy the fun of low temperature cooking

Try out strong

Suitable for various types of POTS and pans

智能调温

让您在 16-93 度间自由调节水温

快速解冻

让您在省时同时保证食物成分不流失

恒温保持

完全解放您的操作时间

多模式选择

让您享受对低温烹饪的乐趣

试用性强

适合多种类型的盆、锅使用



SV5088

低温烹饪机

> Sous Vide-Immersion Circulator,(Head Only)



SV6088

低温烹饪机

> Sous Vide-Immersion Circulator,(Head Only)



型号	额定功率	额定电压	额定频率	
SV5088	1200W	220-240V~	50/60HZ	适用 10A 国际插头
SV6088	1200W	220-240V~	50/60HZ	适用 10A 国际插头

FOOD VACUUM MACHINE
食品真空包装机系列

This machine is mainly used for sealing flexible packaging materials such as composite film and aluminum foil composite film. It can pack solid, liquid, powder, paste and other properties in vacuum

本机主要用于复合薄膜和铝箔复合膜等软包装材料的封口包装可对固体、液体、粉状、糊状等性质物理进行真空包装

KI280

食品真空包装机

> Vacuum Machine



KI400E

食品真空包装机

> Vacuum Machine



KI250C

食品真空包装机

> Vacuum Machine



KI300T

食品真空包装机

> Vacuum Machine



型号	额定功率	额定电压	额定频率	
KI280	400W	220-240V~	50/60HZ	适用 10A 国际插头
KI400E	400W	220-240V~	50/60HZ	适用 10A 国际插头
KI250C	400W	220-240V~	50/60HZ	适用 10A 国际插头
KI300T	400W	220-240V~	50/60HZ	适用 10A 国际插头

CREATOR OF THE ATMOSPHERE MAKER

我们生产的不止是容器
更是品质餐饮的氛围缔造者



CHAFING DISH
餐炉类



CH204

冷热可切换餐炉

Cold and Hot food love this Chafing Dish

行业之先锐，实现加热和制冷之间相互切换，诠释餐炉新概念。

CH204M

冷热可切换餐炉

Temperature at -2°C(36°F)-85°C(185°F) for freely control.

温度可在 -2°C~85°C 自由调控，冰热世界，在于掌控这间。

COLD

HOT



型号	额定功率	额定电压	适用 10A 国际插头
CH204	320W	220-240V~	

型号	额定功率	额定电压	适用 10A 国际插头
CH204M(手动)	320W	220-240V~	

NEW TC SERIES

全新 TC 调温系列

NEW TC TEMPERATURE REGULATION SERIES FOR SOUP AND MEAL STOVES

Humanized design, environmental protection and energy saving
The temperature can be adjusted between 40 °C and 85 °C to keep the food delicious and fresh

The original soup stove and meal stove products can be added with temperature control function, and the product model with temperature control function is to add "Tc-" before the prototype number.

For example, the original product model is "s2403", and the product model with temperature control function is "tc-s2403".

全线汤炉、餐炉产品新增 TC 调温系列

人性化设计，环保节能

温度可按需在 40°C ~85°C 之间随意调节，

保持食品的美味和新鲜

原汤炉、餐炉产品都可增加调温功能，增加温控功能的产品型号

为在原型号前添加“TC-”。

例如：原产品型号为“S2403”，增加温控功能的产品型号为

“TC-S2403”。

TCS24 SERIES (系列)

TCS2401-1 / TCS2401-2

TCS2402-1 / TCS2402-2

温控可视镀金 / 铬长方形宴会餐炉

- > Oblong Chafing Dish
- > Gilt / Chrome Legs
- > Show Window
- > Temperature Control



型号	容量	额定功率	额定电压	额定频率	
TCS2401-1 (单格 Single)	8.3L	250W	220-240V~	50/60HZ	适用 10A 国际插头
TCS2401-2 (双格 Double)	4L*2	250W	220-240V~	50/60HZ	适用 10A 国际插头
TCS2402-1 (单格 Single)	8.3L	250W	220-240V~	50/60HZ	适用 10A 国际插头
TCS2402-2 (双格 Double)	4L*2	250W	220-240V~	50/60HZ	适用 10A 国际插头



TCS2401-1 / TCS2401-2

TCS2402-1 / TCS2402-2

TCS2403 / TCS2404

温控可视镀金 / 铬球形宴会餐炉

- > Round Chafing Dish
- > Gilt / Chrome Legs
- > Show Window
- > Temperature Control



型号	容量	额定功率	额定电压	额定频率	
TCS2403	6L	250W	220-240V~	50/60HZ	适用 10A 国际插头
TCS2404	6L	250W	220-240V~	50/60HZ	适用 10A 国际插头



TCS2403

TCS2404

TCS2405 / TCS2406

温控可视镀金 / 铬长方形宴会汤炉

- > Oblong Soup Station
- > Gilt / Chrome Legs
- > Show Window
- > Temperature Control



型号	容量	额定功率	额定电压	额定频率	
TCS2405	4.6L*2	250W	220-240V~	50/60HZ	适用 10A 国际插头
TCS2406	4.6L*2	250W	220-240V~	50/60HZ	适用 10A 国际插头



TCS2405

TCS2406

TCS2407 / TCS2408

温控可视镀金 / 铬球形宴会汤炉

- > Round Soup Station
- > Gilt / Chrome Legs
- > Show Window
- > Temperature Control



型号	容量	额定功率	额定电压	额定频率	
TCS2407	4.6L	250W	220-240V~	50/60HZ	适用 10A 国际插头
TCS2408	4.6L	250W	220-240V~	50/60HZ	适用 10A 国际插头



TCS2407

TCS2408

TCS68 SERIES (系列)

TCS6801-1 / TCS6801-2

TCS6801G-1 / TCS6801G-2

温控可视镀金 / 铬长方形宴会餐炉

- > Oblong Chafing Dish
- > Gilt / Chrome Legs
- > Show Window
- > Temperature Control



TCS6801-1 / TCS6801-2



TCS6801G-1 / TCS6801G-2

型号	容量	额定功率	额定电压	额定频率	
TCS6801-1 (单格 Single)	8.3L	250W	220-240V~	50/60HZ	适用 10A 国际插头
TCS6801-2 (双格 Double)	4L*2	250W	220-240V~	50/60HZ	适用 10A 国际插头
TCS6801G-1 (单格 Single)	8.3L	250W	220-240V~	50/60HZ	适用 10A 国际插头
TCS6801G-2 (双格 Double)	4L*2	250W	220-240V~	50/60HZ	适用 10A 国际插头

TCS6803 / TCS6803G

温控可视镀金 / 铬球形宴会餐炉

- > Round Chafing Dish
- > Gilt / Chrome Legs
- > Show Window
- > Temperature Control



TCS6803



TCS6803G

型号	容量	额定功率	额定电压	额定频率	
TCS6803	6L	250W	220-240V~	50/60HZ	适用 10A 国际插头
TCS6803G	6L	250W	220-240V~	50/60HZ	适用 10A 国际插头

TCS6805 / TCS6805G

温控可视镀金 / 铬长方形宴会汤炉

- > Oblong Soup Station
- > Gilt / Chrome Legs
- > Show Window
- > Temperature Control



TCS6805



TCS6805G

型号	容量	额定功率	额定电压	额定频率	
TCS6805	4.6L*2	250W	220-240V~	50/60HZ	适用 10A 国际插头
TCS6805G	4.6L*2	250W	220-240V~	50/60HZ	适用 10A 国际插头

TCS6807 / TCS6807G

温控可视镀金 / 铬球形宴会汤炉

- > Round Soup Station
- > Gilt / Chrome Legs
- > Show Window
- > Temperature Control



TCS6807



TCS6807G

型号	容量	额定功率	额定电压	额定频率	
TCS6807	4.6L	250W	220-240V~	50/60HZ	适用 10A 国际插头
TCS6807G	4.6L	250W	220-240V~	50/60HZ	适用 10A 国际插头

TCS67 SERIES (系列)

TCS6701-1 / TCS6701-2

TCS6701G-1 / TCS6701G-2

温控可视镀金 / 铬长方形宴会餐炉

- > Oblong Chafing Dish
- > Gilt / Chrome Legs
- > Show Window
- > Temperature Control



TCS6701-1 / TCS6701-2



TCS6701G-1 / TCS6701G-2

型号	容量	额定功率	额定电压	额定频率	
TCS6701-1 (单格 Single)	8.3L	250W	220-240V~	50/60HZ	适用 10A 国际插头
TCS6701-2 (双格 Double)	4L*2	250W	220-240V~	50/60HZ	适用 10A 国际插头
TCS6701G-1 (单格 Single)	8.3L	250W	220-240V~	50/60HZ	适用 10A 国际插头
TCS6701G-2 (双格 Double)	4L*2	250W	220-240V~	50/60HZ	适用 10A 国际插头

TCS6703 / TCS6703G

温控可视镀金 / 铬球形宴会餐炉

- > Round Chafing Dish
- > Gilt / Chrome Legs
- > Show Window
- > Temperature Control



TCS6703



TCS6703G

型号	容量	额定功率	额定电压	额定频率	
TCS6703	6L	250W	220-240V~	50/60HZ	适用 10A 国际插头
TCS6703G	6L	250W	220-240V~	50/60HZ	适用 10A 国际插头

TCS6705 / TCS6705G

温控可视镀金 / 铬长方形宴会汤炉

- > Oblong Soup Station
- > Gilt / Chrome Legs
- > Show Window
- > Temperature Control



TCS6705



TCS6705G

型号	容量	额定功率	额定电压	额定频率	
TCS6705	4.6L*2	250W	220-240V~	50/60HZ	适用 10A 国际插头
TCS6705G	4.6L*2	250W	220-240V~	50/60HZ	适用 10A 国际插头

TCS6707 / TCS6707G

温控可视镀金 / 铬球形宴会汤炉

- > Round Soup Station
- > Gilt / Chrome Legs
- > Show Window
- > Temperature Control



TCS6707



TCS6707G

型号	容量	额定功率	额定电压	额定频率	
TCS6707	4.6L	250W	220-240V~	50/60HZ	适用 10A 国际插头
TCS6707G	4.6L	250W	220-240V~	50/60HZ	适用 10A 国际插头

TCS67/65 SERIES (系列)

TCS6702-1 / TCS6702-2

TCS6501-1 / TCS6501-2

温控可视全钢长方型宴会餐炉

- > Oblong Chafing Dish
- > Show Window
- > s.s Legs
- > Temperature Control



TCS6702-1 / TCS6702-2



TCS6501-1 / TCS6501-2

型号	容量	额定功率	额定电压	额定频率	
TCS6702-1 (单格 Single)	8.3L	250W	220-240V~	50/60HZ	适用 10A 国际插头
TCS6702-2 (双格 Double)	4L*2	250W	220-240V~	50/60HZ	适用 10A 国际插头
TCS6501-1 (单格 Single)	8.3L	250W	220-240V~	50/60HZ	适用 10A 国际插头
TCS6501-2 (双格 Double)	4L*2	250W	220-240V~	50/60HZ	适用 10A 国际插头

TCS6704 / TCS6503

温控可视全钢球型宴会餐炉

- > Round Chafing Dish
- > Show Window
- > s.s Legs
- > Temperature Control



TCS6704



TCS6503

型号	容量	额定功率	额定电压	额定频率	
TCS6704	6L	250W	220-240V~	50/60HZ	适用 10A 国际插头
TCS6503	6L	250W	220-240V~	50/60HZ	适用 10A 国际插头

TCS6706 / TCS6505

温控可视全钢长方型宴会汤炉

- > Oblong Soup Station
- > Show Window
- > s.s Legs
- > Temperature Control



TCS6706



TCS6505

型号	容量	额定功率	额定电压	额定频率	
TCS6706	4.6L*2	250W	220-240V~	50/60HZ	适用 10A 国际插头
TCS6505	4.6L*2	250W	220-240V~	50/60HZ	适用 10A 国际插头

TCS6708 / TCS6507

温控可视全钢球型宴会汤炉

- > Round Soup Station
- > Show Window
- > s.s Legs
- > Temperature Control



TCS6708



TCS6507

型号	容量	额定功率	额定电压	额定频率	
TCS6708	4.6L	250W	220-240V~	50/60HZ	适用 10A 国际插头
TCS6507	4.6L	250W	220-240V~	50/60HZ	适用 10A 国际插头

TCB24 SERIES (系列)

TCB2401-1 / TCB2401-2

TCB2402-1 / TCB2402-2

温控镀金 / 镀铬长方型宴会餐炉

- > Oblong Chafing Dish
- > Temperature Control
- > gilt/chorme Legs



TCB2401-1/TCB2401-2



TCB2402-1/TCB2402-2

型号	容量	额定功率	额定电压	额定频率	
TCB2401-1 (单格 Single)	8.3L	250W	220-240V~	50/60HZ	适用 10A 国际插头
TCB2401-2 (双格 Double)	4L*2	250W	220-240V~	50/60HZ	适用 10A 国际插头
TCB2402-1 (单格 Single)	8.3L	250W	220-240V~	50/60HZ	适用 10A 国际插头
TCB2402-2 (双格 Double)	4L*2	250W	220-240V~	50/60HZ	适用 10A 国际插头

TCB2403 / TCB2404

温控镀金 / 镀铬球型宴会餐炉

- > Round Chafing Dish
- > Temperature Control
- > gilt/chorme Legs



TCB2403



TCB2404

型号	容量	额定功率	额定电压	额定频率	
TCB2403	6L	250W	220-240V~	50/60HZ	适用 10A 国际插头
TCB2404	6L	250W	220-240V~	50/60HZ	适用 10A 国际插头

TCB2405 / TCB2406

温控可视镀金 / 镀铬长方型宴会汤炉

- > Oblong Soup Station
- > Temperature Control
- > gilt/chorme Legs



TCB2405



TCB2406

型号	容量	额定功率	额定电压	额定频率	
TCB2405	4.6L*2	250W	220-240V~	50/60HZ	适用 10A 国际插头
TCB2406	4.6L*2	250W	220-240V~	50/60HZ	适用 10A 国际插头

TCB2407 / TCB2408

温控可视镀金 / 镀铬球型宴会汤炉

- > Round Soup Station
- > Temperature Control
- > Gilt / Chrome Legs



TCB2407



TCB2408

型号	容量	额定功率	额定电压	额定频率	
TCB2407	4.6L	250W	220-240V~	50/60HZ	适用 10A 国际插头
TCB2408	4.6L	250W	220-240V~	50/60HZ	适用 10A 国际插头

TCB68 SERIES (系列)

TCB6801-1 / TCB6801-2

TCB6801G-1 / TCB6801G-2

温控可视全钢长方型宴会餐炉

> Oblong Chafing Dish > Temperature Control
> Gilt / Chrome Legs

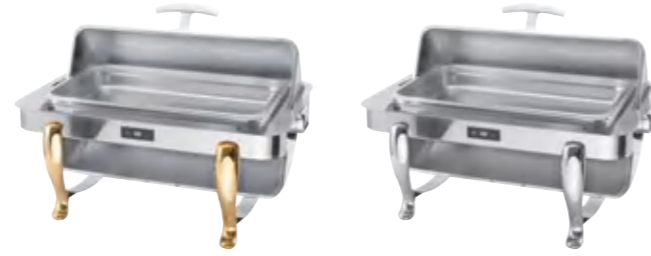

TCB6801-1/TCB6801-2

TCB6801G-1/TCB6801G-2

型号	容量	额定功率	额定电压	额定频率	
TCB6801-1 (单格 Single)	8.3L	250W	220-240V~	50/60HZ	适用 10A 国际插头
TCB6801-2 (双格 Double)	4L*2	250W	220-240V~	50/60HZ	适用 10A 国际插头
TCB6801G-1 (单格 Single)	8.3L	250W	220-240V~	50/60HZ	适用 10A 国际插头
TCB6801G-2 (双格 Double)	4L*2	250W	220-240V~	50/60HZ	适用 10A 国际插头

TCB6803 / TCB6803G

温控镀金全翻盖球形宴会餐炉

> Round Chafing Dish > Temperature Control
> Gilt / Chrome Legs



TCB6803

TCB6803G

型号	容量	额定功率	额定电压	额定频率	
TCB6803	6L	250W	220-240V~	50/60HZ	适用 10A 国际插头
TCB6803G	6L	250W	220-240V~	50/60HZ	适用 10A 国际插头

TCB6805 / TCB6805G

温控可视全钢长方型宴会汤炉

> Oblong Soup Station > Temperature Control
> Gilt / Chrome Legs



TCB6805

TCB6805G

型号	容量	额定功率	额定电压	额定频率	
TCB6805	4.6L*2	250W	220-240V~	50/60HZ	适用 10A 国际插头
TCB6805G	4.6L*2	250W	220-240V~	50/60HZ	适用 10A 国际插头

TCB6807 / TCB6807G

温控镀金 / 铬全翻盖球形宴会汤炉

> Round Chafing Dish > Temperature Control
> Gilt / Chrome Legs



TCB6807

TCB6807G

型号	容量	额定功率	额定电压	额定频率	
TCB6807	4.6L	250W	220-240V~	50/60HZ	适用 10A 国际插头
TCB6807G	4.6L	250W	220-240V~	50/60HZ	适用 10A 国际插头

TCB67 SERIES (系列)

TCB6701-1 / TCB6701-2

TCB6701G-1 / TCB6701G-2

温控镀金 / 镀铬长方型宴会餐炉

> Oblong Chafing Dish > Temperature Control
> Gilt / Chrome Legs



TCB6701-1/TCB6701-2

TCB6701G-1/TCB6701G-2

型号	容量	额定功率	额定电压	额定频率	
TCB6701-1 (单格 Single)	8.3L	250W	220-240V~	50/60HZ	适用 10A 国际插头
TCB6701-2 (双格 Double)	4L*2	250W	220-240V~	50/60HZ	适用 10A 国际插头
TCB6701G-1 (单格 Single)	8.3L	250W	220-240V~	50/60HZ	适用 10A 国际插头
TCB6701G-2 (双格 Double)	4L*2	250W	220-240V~	50/60HZ	适用 10A 国际插头

TCB6703 / TCB6703G

温控镀金全翻盖球形宴会餐炉

> Round Chafing Dish > Temperature Control
> Gilt / Chrome Legs



TCB6703

TCB6703G

型号	容量	额定功率	额定电压	额定频率	
TCB6703	6L	250W	220-240V~	50/60HZ	适用 10A 国际插头
TCB6703G	6L	250W	220-240V~	50/60HZ	适用 10A 国际插头

TCB6705 / TCB6705G

温控镀金全翻盖双头宴会汤炉

> Oblong Soup Station > Temperature Control
> Gilt / Chrome Legs

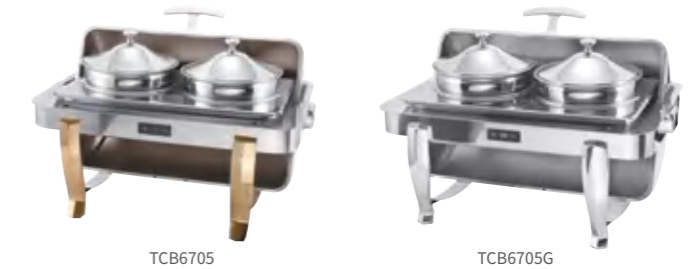

TCB6705

TCB6705G

型号	容量	额定功率	额定电压	额定频率	
TCB6705	4.6L*2	250W	220-240V~	50/60HZ	适用 10A 国际插头
TCB6705G	4.6L*2	250W	220-240V~	50/60HZ	适用 10A 国际插头

TCB6707 / TCB6707G

温控镀金全翻盖球形宴会汤炉

> Round Soup Station > Temperature Control
> Gilt Legs



TCB6707

TCB6707G

型号	容量	额定功率	额定电压	额定频率	
TCB6707	4.6L	250W	220-240V~	50/60HZ	适用 10A 国际插头
TCB6707G	4.6L	250W	220-240V~	50/60HZ	适用 10A 国际插头

TCB67/65 SERIES (系列)

TCB6702-1 / TCB6702-2

TCB6501-1 / TCB6501-2

温控全钢全翻盖单 / 双格宴会餐炉

- > Oblong Chafing Dish
- > s.s Legs
- > Temperature Control



TCB6702-1 / TCB6702-2



TCB6501-1 / TCB6501-2

型号	容量	额定功率	额定电压	额定频率	
TCB6702-1 (单格 Single)	单 8.3L / 双 4L*2	250W	220-240V~	50/60HZ	适用 10A 国际插头
TCS6702-2 (双格 Double)	单 8.3L / 双 4L*2	250W	220-240V~	50/60HZ	适用 10A 国际插头
TCB6501-1 (单格 Single)	单 8.3L / 双 4L*2	250W	220-240V~	50/60HZ	适用 10A 国际插头
TCB6501-2 (双格 Double)	单 8.3L / 双 4L*2	250W	220-240V~	50/60HZ	适用 10A 国际插头

TCB6704 / TCS6503

温控全钢全翻盖球形宴会餐炉

- > Round Chafing Dish
- > s.s Legs
- > Temperature Control



TCB6704



TCS6503

型号	容量	额定功率	额定电压	额定频率	
TCB6704	6L	250W	220-240V~	50/60HZ	适用 10A 国际插头
TCS6503	6L	250W	220-240V~	50/60HZ	适用 10A 国际插头

TCB6706 / TCS6505

温控全钢全翻盖双头宴会汤炉

- > Oblong Soup Station
- > s.s Legs
- > Temperature Control



TCB6706



TCS6505

型号	容量	额定功率	额定电压	额定频率	
TCB6706	4.6L*2	250W	220-240V~	50/60HZ	适用 10A 国际插头
TCS6505	4.6L*2	250W	220-240V~	50/60HZ	适用 10A 国际插头

TCB6708 / TCS6507

温控全钢全翻盖球形宴会汤炉

- > Round Soup Station
- > s.s Legs
- > Temperature Control



TCB6708



TCS6507

型号	容量	额定功率	额定电压	额定频率	
TCB6708	4.6L	250W	220-240V~	50/60HZ	适用 10A 国际插头
TCS6507	4.6L	250W	220-240V~	50/60HZ	适用 10A 国际插头

TOUCH M SERIES 触动系列



TOUCH THE "OPEN" AND "CLOSE", THE COVER WILL OPEN OR CLOSE AUTOMATIC.

The inductor under the control panel, when you leave it 2-5 seconds, the cover will closed automatic. Automatic system, Human-centered Design, Energy-saving and environment-friendly product. Safety and Health.

Everlasting mechanism. The temperature can be adjusted from 40°C(104°F)~85°C(185°F).

使用者可轻触控制面板的“OPEN”和“CLOSE”按钮，可将翻盖调至半翻，全翻和闭合状态。

控制面板的中间部分内藏感应器，使用者取物离开数秒后会自动恢复合盖状态。翻盖在关闭过程中会自动感应是否需要恢复半翻盖状态。人性化设计，环保节能，安全卫生。

已做安全抗疲劳，超强度运作测试，优于传统装置。设有温控功能装置，温度可按需在 40°C~85°C 之是随意调节。

M24 SERIES (系列)

M2401-1 / M2401-2

M2402-1 / M2402-2

电动可视镀金 / 铬长方形宴会餐炉

- > Oblong Chafing Dish
- > Gilt / Chrome Legs
- > Show Window
- > Automatic Open



型号	容量	额定功率	额定电压	额定频率	
M2401-1 (单格 Single)	8.3L	250W	220-240V~	50/60HZ	适用 10A 国际插头
M2401-2 (双格 Double)	4L*2	250W	220-240V~	50/60HZ	适用 10A 国际插头
M2402-1 (单格 Single)	8.3L	250W	220-240V~	50/60HZ	适用 10A 国际插头
M2402-2 (双格 Double)	4L*2	250W	220-240V~	50/60HZ	适用 10A 国际插头



M2401-1 / M2401-2



M2402-1 / M2402-2

M2403 / M2404

电动可视镀金 / 铬长方形宴会餐炉

- > Round Chafing Dish
- > Gilt / Chrome Legs
- > Show Window
- > Automatic Open



型号	容量	额定功率	额定电压	额定频率	
M2403	6L	250W	220-240V~	50/60HZ	适用 10A 国际插头
M2404	6L	250W	220-240V~	50/60HZ	适用 10A 国际插头



M2403



M2404

M2405 / M2406

电动可视镀金 / 铬长方形宴会汤炉

- > Oblong Soup Station
- > Gilt / Chrome Legs
- > Show Window
- > Automatic Open



型号	容量	额定功率	额定电压	额定频率	
M2405	4.6L*2	250W	220-240V~	50/60HZ	适用 10A 国际插头
M2406	4.6L*2	250W	220-240V~	50/60HZ	适用 10A 国际插头



M2405



M2406

M2407 / M2408

电动可视镀金 / 铬球型宴会汤炉

- > Round Soup Station
- > Gilt / Chrome Legs
- > Show Window
- > Automatic Open



型号	容量	额定功率	额定电压	额定频率	
M2407	4.6L	250W	220-240V~	50/60HZ	适用 10A 国际插头
M2408	4.6L	250W	220-240V~	50/60HZ	适用 10A 国际插头



M2407



M2408

M68 SERIES (系列)

M6801-1 / M6801-2

M6801G-1 / M6801G-2

电动可视镀金 / 铬长方形宴会餐炉

- > Oblong Chafing Dish
- > Gilt / Chrome Legs
- > Show Window
- > Automatic Open



型号	容量	额定功率	额定电压	额定频率	
M6801-1 (单格 Single)	8.3L	250W	220-240V~	50/60HZ	适用 10A 国际插头
M6801-2 (双格 Double)	4L*2	250W	220-240V~	50/60HZ	适用 10A 国际插头
M6801G-1 (单格 Single)	8.3L	250W	220-240V~	50/60HZ	适用 10A 国际插头
M6801G-2 (双格 Double)	4L*2	250W	220-240V~	50/60HZ	适用 10A 国际插头



M6801-1 / M6801-2



M6801G-1 / M6801G-2

M6803 / M6803G

电动可视镀金 / 铬球型宴会餐炉

- > Round Chafing Dish
- > Gilt / Chrome Legs
- > Show Window
- > Automatic Open



型号	容量	额定功率	额定电压	额定频率	
M6803	6L	250W	220-240V~	50/60HZ	适用 10A 国际插头
M6803G	6L	250W	220-240V~	50/60HZ	适用 10A 国际插头



M6803



M6803G

M6805 / M6805G

电动可视镀金 / 铬长方形宴会汤炉

- > Oblong Soup Station
- > Gilt / Chrome Legs
- > Show Window
- > Automatic Open



型号	容量	额定功率	额定电压	额定频率	
M6805	4.6L*2	250W	220-240V~	50/60HZ	适用 10A 国际插头
M6805G	4.6L*2	250W	220-240V~	50/60HZ	适用 10A 国际插头



M6805



M6805G

M6807 / M6807G

电动可视镀金 / 铬球型宴会汤炉

- > Round Soup Station
- > Gilt / Chrome Legs
- > Show Window
- > Automatic Open



型号	容量	额定功率	额定电压	额定频率	
M6807	4.6L	250W	220-240V~	50/60HZ	适用 10A 国际插头
M6807G	4.6L	250W	220-240V~	50/60HZ	适用 10A 国际插头



M6807



M6807G

M67 SERIES (系列)

M6701-1 / M6701-2

M6701G-1 / M6701G-2

电动可视镀金 / 铬长方型宴会餐炉

- > Oblong Chafing Dish
- > Gilt / Chrome Legs
- > Show Window
- > Automatic Open



M6701-1 / M6701-2



M6701G-1 / M6701G-2

型号	容量	额定功率	额定电压	额定频率	
M6701-1 (单格 Single)	8.3L	250W	220-240V~	50/60HZ	适用 10A 国际插头
M6701-2 (双格 Double)	4L*2	250W	220-240V~	50/60HZ	适用 10A 国际插头
M6701G-1 (单格 Single)	8.3L	250W	220-240V~	50/60HZ	适用 10A 国际插头
M6701G-2 (双格 Double)	4L*2	250W	220-240V~	50/60HZ	适用 10A 国际插头

M6703 / M6703G

电动可视镀金 / 铬球型宴会餐炉

- > Round Chafing Dish
- > Gilt / Chrome Legs
- > Show Window
- > Automatic Open



M6703



M6703G

型号	容量	额定功率	额定电压	额定频率	
M6703	6L	250W	220-240V~	50/60HZ	适用 10A 国际插头
M6703G	6L	250W	220-240V~	50/60HZ	适用 10A 国际插头

M6705 / M6705G

电动可视镀金 / 铬长方型宴会汤炉

- > Oblong Soup Station
- > Gilt / Chrome Legs
- > Show Window
- > Automatic Open



M6705



M6705G

型号	容量	额定功率	额定电压	额定频率	
M6705	4.6L*2	250W	220-240V~	50/60HZ	适用 10A 国际插头
M6705G	4.6L*2	250W	220-240V~	50/60HZ	适用 10A 国际插头

M6707 / M6707G

电动可视镀金 / 铬球型宴会汤炉

- > Round Soup Station
- > Gilt / Chrome Legs
- > Show Window
- > Automatic Open



M6707



M6707G

型号	容量	额定功率	额定电压	额定频率	
M6707	4.6L	250W	220-240V~	50/60HZ	适用 10A 国际插头
M6707G	4.6L	250W	220-240V~	50/60HZ	适用 10A 国际插头

M67/M65 SERIES (系列)

M6702-1 / M6702-2

M6501-1 / M6501-2

电动可视全钢长方型宴会餐炉

- > Oblong Chafing Dish
- > s.s Legs
- > Show Window
- > Automatic Open



M6702-1 / M6702-2



M6501-1 / M6501-2

型号	容量	额定功率	额定电压	额定频率	
M6702-1 (单格 Single)	8.3L	250W	220-240V~	50/60HZ	适用 10A 国际插头
M6702-2 (双格 Double)	4L*2	250W	220-240V~	50/60HZ	适用 10A 国际插头
M6501-1 (单格 Single)	8.3L	250W	220-240V~	50/60HZ	适用 10A 国际插头
M6501-2 (双格 Double)	4L*2	250W	220-240V~	50/60HZ	适用 10A 国际插头

M6704 / M6503

电动可视全钢球型宴会餐炉

- > Round Chafing Dish
- > s.s Legs
- > Show Window
- > Automatic Open



M6704



M6503

型号	容量	额定功率	额定电压	额定频率	
M6704	6L	250W	220-240V~	50/60HZ	适用 10A 国际插头
M6503	6L	250W	220-240V~	50/60HZ	适用 10A 国际插头

M6706 / M6505

电动可视全钢长方型宴会汤炉

- > Oblong Soup Station
- > s.s Legs
- > Show Window
- > Automatic Open



M6706



M6505

型号	容量	额定功率	额定电压	额定频率	
M6706	4.6L*2	250W	220-240V~	50/60HZ	适用 10A 国际插头
M6505	4.6L*2	250W	220-240V~	50/60HZ	适用 10A 国际插头

M6708 / M6507

电动可视全钢球型宴会汤炉

- > Round Soup Station
- > s.s Legs
- > Show Window
- > Automatic Open



M6708



M6507

型号	容量	额定功率	额定电压	额定频率	
M6708	4.6L	250W	220-240V~	50/60HZ	适用 10A 国际插头
M6507	4.6L	250W	220-240V~	50/60HZ	适用 10A 国际插头

H24 SERIES (系列)

H2401-1 / H2401-2

H2402-1 / H2402-2

电动全钢全翻盖球形宴会汤炉

- > Oblong Chafing Dish > Automatic Open
> Gilt / Chrome Legs



型号	容量	额定功率	额定电压	额定频率	
H2401-1 (单格 Single)	8.3L	250W	220-240V~	50/60HZ	适用 10A 国际插头
H2401-2 (双格 Double)	4L*2	250W	220-240V~	50/60HZ	适用 10A 国际插头
H2402-1 (单格 Single)	8.3L	250W	220-240V~	50/60HZ	适用 10A 国际插头
H2402-2 (双格 Double)	4L*2	250W	220-240V~	50/60HZ	适用 10A 国际插头



H2401-1/H2401-2

H2402-1/H2402-2

H2403 / H2404

电动可视镀金 / 铬球型宴会餐炉

- > Round Chafing Dish > Automatic Open
> Gilt / Chrome Legs



型号	容量	额定功率	额定电压	额定频率	
H2403	6L	250W	220-240V~	50/60HZ	适用 10A 国际插头
H2404	6L	250W	220-240V~	50/60HZ	适用 10A 国际插头



H2403

H2404

H2405 / H2406

电动镀金 / 镀铬全翻盖双头宴会汤炉

- > Oblong Soup Station > Automatic Open
> Gilt / Chrome Legs



型号	容量	额定功率	额定电压	额定频率	
H2405	4.6L*2	250W	220-240V~	50/60HZ	适用 10A 国际插头
H2406	4.6L*2	250W	220-240V~	50/60HZ	适用 10A 国际插头



H2405

H2406

H2407 / H2408

电动镀金全翻盖球形宴会汤炉

- > Round Soup Station > Automatic Open
> Gilt / Chrome Legs



型号	容量	额定功率	额定电压	额定频率	
H2407	4.6L	250W	220-240V~	50/60HZ	适用 10A 国际插头
H2408	4.6L	250W	220-240V~	50/60HZ	适用 10A 国际插头



H2407

H2408

H68 SERIES (系列)

H6801-1 / H6801-2

H6801G-1 / H6801G-2

电动可视全钢长方形宴会餐炉

- > Oblong Chafing Dish > Automatic Open
> Gilt / Chrome Legs



型号	容量	额定功率	额定电压	额定频率	
H6801-1 (单格 Single)	8.3L	250W	220-240V~	50/60HZ	适用 10A 国际插头
H6801-2 (双格 Double)	4L*2	250W	220-240V~	50/60HZ	适用 10A 国际插头
H6801G-1 (单格 Single)	8.3L	250W	220-240V~	50/60HZ	适用 10A 国际插头
H6801G-2 (双格 Double)	4L*2	250W	220-240V~	50/60HZ	适用 10A 国际插头



H6801-1 / H6801-2

H6803 / H6803G

电动镀金 / 铬全翻盖球形宴会餐炉

- > Round Chafing Dish > Automatic Open
> Gilt / Chrome Legs



型号	容量	额定功率	额定电压	额定频率	
H6803	6L	250W	220-240V~	50/60HZ	适用 10A 国际插头
H6803G	6L	250W	220-240V~	50/60HZ	适用 10A 国际插头



H6803

H6803G

H6805 / H6805G

电动镀金 / 铬全翻盖双头宴会汤炉

- > Oblong Soup Station > Automatic Open
> Gilt / Chrome Legs



型号	容量	额定功率	额定电压	额定频率	
H6805	4.6L*2	250W	220-240V~	50/60HZ	适用 10A 国际插头
H6805G	4.6L*2	250W	220-240V~	50/60HZ	适用 10A 国际插头



H6805

H6805G

H6807 / H6807G

电动镀金全翻盖球形宴会汤炉

- > Round Soup Station > Automatic Open
> Gilt/Chrome Legs



型号	容量	额定功率	额定电压	额定频率	
H6807	4.6L	250W	220-240V~	50/60HZ	适用 10A 国际插头
H6807G	4.6L	250W	220-240V~	50/60HZ	适用 10A 国际插头



H6807

H6807G

H67 SERIES (系列)

H6701-1 / H6701-2

H6701G-1 / H6701G-2

电动镀金全翻盖单 / 双格宴会餐炉

- > Oblong Chafing Dish
- > Gilt / Chrome Legs
- > Automatic Open



型号	容量	额定功率	额定电压	额定频率	
H6701-1 (单格 Single)	8.3L	250W	220-240V~	50/60HZ	适用 10A 国际插头
H6701-2 (双格 Double)	4L*2	250W	220-240V~	50/60HZ	适用 10A 国际插头
H6701G-1 (单格 Single)	8.3L	250W	220-240V~	50/60HZ	适用 10A 国际插头
H6701G-2 (双格 Double)	4L*2	250W	220-240V~	50/60HZ	适用 10A 国际插头



H6703 / H6703G

电动镀金 / 铬全翻盖球形宴会餐炉

- > Round Chafing Dish
- > Gilt / Chrome Legs
- > Automatic Open



型号	容量	额定功率	额定电压	额定频率	
H6703	6L	250W	220-240V~	50/60HZ	适用 10A 国际插头
H6703G	6L	250W	220-240V~	50/60HZ	适用 10A 国际插头



H6705 / H6705G

电动镀金全翻盖双头宴会汤炉

- > Oblong Soup Station
- > Gilt / Chrome Legs
- > Automatic Open



型号	容量	额定功率	额定电压	额定频率	
H6705	4.6L*2	250W	220-240V~	50/60HZ	适用 10A 国际插头
H6705G	4.6L*2	250W	220-240V~	50/60HZ	适用 10A 国际插头



H6707 / H6707G

电动镀金全翻盖球形宴会汤炉

- > Round Soup Station
- > Gilt / Chrome Legs
- > Automatic Open



型号	容量	额定功率	额定电压	额定频率	
H2407	4.6L	250W	220-240V~	50/60HZ	适用 10A 国际插头
H2407G	4.6L	250W	220-240V~	50/60HZ	适用 10A 国际插头



H67/H65 SERIES (系列)

H6702-1 / H6702-2

H6501-1 / H6501-2

电动镀金全翻盖单 / 双格宴会餐炉

- > Oblong Chafing Dish
- > s.s Legs
- > Automatic Open



型号	容量	额定功率	额定电压	额定频率	
H6702-1 (单格 Single)	8.3L	250W	220-240V~	50/60HZ	适用 10A 国际插头
H6702-2 (双格 Double)	4L*2	250W	220-240V~	50/60HZ	适用 10A 国际插头
H6501-1 (单格 Single)	8.3L	250W	220-240V~	50/60HZ	适用 10A 国际插头
H6501-2 (双格 Double)	4L*2	250W	220-240V~	50/60HZ	适用 10A 国际插头



H6704 / H6503

电动全钢全翻盖球形宴会餐炉

- > Round Chafing Dish
- > s.s Legs
- > Automatic Open



型号	容量	额定功率	额定电压	额定频率	
H6704	6L	250W	220-240V~	50/60HZ	适用 10A 国际插头
H6503	6L	250W	220-240V~	50/60HZ	适用 10A 国际插头



H6706 / H6505

电动全钢全翻盖双头宴会汤炉

- > Oblong Soup Station
- > s.s Legs
- > Automatic Open



型号	容量	额定功率	额定电压	额定频率	
H6706	4.6L*2	250W	220-240V~	50/60HZ	适用 10A 国际插头
H6505	4.6L*2	250W	220-240V~	50/60HZ	适用 10A 国际插头



H6708 / H6507

电动全钢全翻盖球形宴会汤炉

- > Round Soup Station
- > s.s Legs
- > Automatic Open



型号	容量	额定功率	额定电压	额定频率	
H6708	4.6L	250W	220-240V~	50/60HZ	适用 10A 国际插头
H6507	4.6L	250W	220-240V~	50/60HZ	适用 10A 国际插头



MD SERIES (系列)

MD201 / MD201G

感应碟菲炉

- > Round 38cm Electrical Chafer
- > Glass / steel Lid
- > Self-opening



MD201

MD201G

型号	容量	额定功率	额定电压	额定频率	
MD201	6L	250W	220-240V~	50/60HZ	配 DB-230 适用 10A 国际插头
MD201G	6L	250W	220-240V~	50/60HZ	配 DB-230 适用 10A 国际插头

MD202 / MD202G

感应碟菲炉

- > Electrical 2/3 GN Chafer
- > Glass / steel Lid
- > Self-opening



MD202

MD202G

型号	容量	额定功率	额定电压	额定频率	
MD202	5.1L	250W	220-240V~	50/60HZ	配 DB-230 适用 10A 国际插头
MD202G	5.1L	250W	220-240V~	50/60HZ	配 DB-230 适用 10A 国际插头

MD204 / MD204G

感应碟菲炉

- > Electrical 1/1 GN Chafer
- > Glass / steel Lid
- > Self-opening



MD204

MD204G

型号	容量	额定功率	额定电压	额定频率	
MD204	单 7.6L 双 3.4L*2	250W	220-240V~	50/60HZ	
MD204G	单 7.6L 双 3.4L*2	250W	220-240V~	50/60HZ	

本公司电磁炉专用 Designed for KINGO Induction Cooker Only

MD101 / MD101G

专用碟菲炉

- > Induction Round 38cm Chafer
- > Glass / Steel Lid
- > Self-opening



MD101

MD101G

MD102 / MD102G

专用碟菲炉

- > Induction 2/3 GN Chafer
- > Glass / Steel Lid
- > Self-opening



MD102

MD102G

SHOW WINDOW S SERIES

可视 S 系列



Special show window

Use the Dupont's high tech material, Original creation making craft, no steam and greasy stain.

可视窗

采用杜邦公司高科技材料，独创制作工艺，可视窗防雾化，防油腻。

sculpt

Perfect design, solid brass legs and line.

造型

精致的脚部造型，线条简约，造型优美。

plane

New style designed in smooth plate, detachable cover for easy cleaning, stronger body to service long life.

平面

采用新型周边平面设计，防侧漏，易擦洗，加固了炉身的强度，延长使用寿命。



S24 SERIES (系列)

标配酒精炉可选配电热板

S2401-1 / S2401-2

S2402-1 / S2402-2

可视镀金 / 铬长方形宴会餐炉

- > Oblong Chafing Dish
- > Gilt / Chrome Legs
- > Show Window



型号	容量	额定功率	额定电压	额定频率	
S2401-1 (单格 Single)	8.3L	380W	220-240V~	50/60HZ	适用 10A 国际插头
S2401-2 (双格 Double)	4L*2	380W	220-240V~	50/60HZ	适用 10A 国际插头
S2402-1 (单格 Single)	8.3L	380W	220-240V~	50/60HZ	适用 10A 国际插头
S2402-2 (双格 Double)	4L*2	380W	220-240V~	50/60HZ	适用 10A 国际插头

S2403 / S2404

可视镀金 / 铬球形宴会餐炉

- > Round Chafing Dish
- > Gilt / Chrome Legs
- > Show Window



型号	容量	额定功率	额定电压	额定频率	
S2403	6L	380W	220-240V~	50/60HZ	适用 10A 国际插头
S2404	6L	380W	220-240V~	50/60HZ	适用 10A 国际插头

S2405 / S2406

可视镀金 / 铬长方形宴会汤炉

- > Oblong Soup Station
- > Gilt / Chrome Legs
- > Show Window



型号	容量	额定功率	额定电压	额定频率	
S2405	4.6L*2	380W	220-240V~	50/60HZ	适用 10A 国际插头
S2406	4.6L*2	380W	220-240V~	50/60HZ	适用 10A 国际插头

S2407 / S2408

可视镀金 / 铬球形宴会汤炉

- > Round Soup Station
- > Gilt / Chrome Legs
- > Show Window



型号	容量	额定功率	额定电压	额定频率	
S2407	4.6L	380W	220-240V~	50/60HZ	适用 10A 国际插头
S2408	4.6L	380W	220-240V~	50/60HZ	适用 10A 国际插头

S68 SERIES (系列)

标配酒精炉可选配电热板

S6801-1 / S6801-2

S6801G-1 / S6801G-2

可视镀金 / 铬长方形宴会餐炉

- > Oblong Chafing Dish
- > Gilt / Chrome Legs
- > Show Window



型号	容量	额定功率	额定电压	额定频率	
S6801-1 (单格 Single)	8.3L	380W	220-240V~	50/60HZ	适用 10A 国际插头
S6801-2 (双格 Double)	4L*2	380W	220-240V~	50/60HZ	适用 10A 国际插头
S6801G-1 (单格 Single)	8.3L	380W	220-240V~	50/60HZ	适用 10A 国际插头
S6801G-2 (双格 Double)	4L*2	380W	220-240V~	50/60HZ	适用 10A 国际插头

S6803 / S6803G

可视镀金 / 铬球形宴会餐炉

- > Round Chafing Dish
- > Gilt / Chrome Legs
- > Show Window



型号	容量	额定功率	额定电压	额定频率	
S6803	6L	380W	220-240V~	50/60HZ	适用 10A 国际插头
S6803G	6L	380W	220-240V~	50/60HZ	适用 10A 国际插头

S6805 / S6805G

可视镀金 / 铬长方形宴会汤炉

- > Oblong Soup Station
- > Gilt / Chrome Legs
- > Show Window

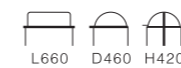

型号	容量	额定功率	额定电压	额定频率	
S6805	4.6L*2	380W	220-240V~	50/60HZ	适用 10A 国际插头
S6805G	4.6L*2	380W	220-240V~	50/60HZ	适用 10A 国际插头

S6807 / S6807G

可视镀金 / 铬球形宴会汤炉

- > Round Soup Station
- > Gilt / Chrome Legs
- > Show Window



型号	容量	额定功率	额定电压	额定频率	
S6807	4.6L	380W	220-240V~	50/60HZ	适用 10A 国际插头
S6807G	4.6L	380W	220-240V~	50/60HZ	适用 10A 国际插头

S67 SERIES (系列)

标配酒精炉可选配电热板

S6701-1 / S6701-2**S6701G-1 / S6701G-2**

可视镀金 / 铬长方型宴会餐炉

- > Oblong Chafing Dish
- > Gilt / Chrome Legs
- > Show Window



S6701-1 / S6701-2

S6701G-1 / S6701G-2

型号	容量	额定功率	额定电压	额定频率	
S6701-1 (单格 Single)	8.3L	380W	220-240V~	50/60HZ	适用 10A 国际插头
S6701-2 (双格 Double)	4L*2	380W	220-240V~	50/60HZ	适用 10A 国际插头
S6701G-1 (单格 Single)	8.3L	380W	220-240V~	50/60HZ	适用 10A 国际插头
S6701G-2 (双格 Double)	4L*2	380W	220-240V~	50/60HZ	适用 10A 国际插头

S6703 / S6703G

可视镀金 / 铬球型宴会餐炉

- > Round Chafing Dish
- > Gilt / Chrome Legs
- > Show Window



S6703

S6703G

型号	容量	额定功率	额定电压	额定频率	
S6703	6L	380W	220-240V~	50/60HZ	适用 10A 国际插头
S6703G	6L	380W	220-240V~	50/60HZ	适用 10A 国际插头

S6705 / S6705G

可视镀金 / 铬长方型宴会汤炉

- > Oblong Soup Station
- > Gilt / Chrome Legs
- > Show Window



S6705

S6705G

型号	容量	额定功率	额定电压	额定频率	
S6705	4.6L*2	380W	220-240V~	50/60HZ	适用 10A 国际插头
S6705G	4.6L*2	380W	220-240V~	50/60HZ	适用 10A 国际插头

S6707 / S6707G

可视镀金 / 铬球型宴会汤炉

- > Round Soup Station
- > Gilt / Chrome Legs
- > Show Window



S6707

S6707G

型号	容量	额定功率	额定电压	额定频率	
S6707	4.6L	380W	220-240V~	50/60HZ	适用 10A 国际插头
S6707G	4.6L	380W	220-240V~	50/60HZ	适用 10A 国际插头

S67/65 SERIES (系列)

标配酒精炉可选配电热板

S6702-1 / S6702-2**S6501-1 / S6501-2**

可视全钢长方型宴会餐炉

- > Oblong Chafing Dish
- > s.s Legs
- > Show Window



S6702-1 / S6702-2

S6501-1 / S6501-2

型号	容量	额定功率	额定电压	额定频率	
S6702-1 (单格 Single)	8.3L	380W	220-240V~	50/60HZ	适用 10A 国际插头
S6801-2 (双格 Double)	4L*2	380W	220-240V~	50/60HZ	适用 10A 国际插头
S6501-1 (单格 Single)	8.3L	380W	220-240V~	50/60HZ	适用 10A 国际插头
S6501-2 (双格 Double)	4L*2	380W	220-240V~	50/60HZ	适用 10A 国际插头

S6704 / S6503

可视全钢球型宴会餐炉

- > Round Chafing Dish
- > s.s Legs
- > Show Window



S6704

S6503

型号	容量	额定功率	额定电压	额定频率	
S6704	6L	380W	220-240V~	50/60HZ	适用 10A 国际插头
S6503	6L	380W	220-240V~	50/60HZ	适用 10A 国际插头

S6706 / S6505

可视全钢长方型宴会汤炉

- > Oblong Soup Station
- > s.s Legs
- > Show Window



S6706

S6505

型号	容量	额定功率	额定电压	额定频率	
S6706	4.6L*2	380W	220-240V~	50/60HZ	适用 10A 国际插头
S6505	4.6L*2	380W	220-240V~	50/60HZ	适用 10A 国际插头

S6708 / S6507

可视全钢球型宴会汤炉

- > Round Soup Station
- > s.s Legs
- > Show Window



S6708

S6507

型号	容量	额定功率	额定电压	额定频率	
S6708	4.6L	380W	220-240V~	50/60HZ	适用 10A 国际插头
S6507	4.6L	380W	220-240V~	50/60HZ	适用 10A 国际插头

B24 SERIES (系列)

标配酒精炉可选配电热板

B2401-1 / B2401-2

B2402-1 / B2402-2

镀金全翻盖单 / 双格宴会餐炉

> Oblong Chafing Dish
> Gilt / Chrome Legs



B2401-1/B2401-2



B2402-1/B2402-2

型号	容量	额定功率	额定电压	额定频率	
B2401-1 (单格 Single)	8.3L	380W	220-240V~	50/60HZ	适用 10A 国际插头
B2401-2 (双格 Double)	4L*2	380W	220-240V~	50/60HZ	适用 10A 国际插头
B2402-1 (单格 Single)	8.3L	380W	220-240V~	50/60HZ	适用 10A 国际插头
B2402-2 (双格 Double)	4L*2	380W	220-240V~	50/60HZ	适用 10A 国际插头

B2403 / B2404

镀金全翻盖双格宴会餐炉

> Round Chafing Dish
> Gilt / Chrome Legs



B2403



B2404

型号	容量	额定功率	额定电压	额定频率	
B2403	6L	380W	220-240V~	50/60HZ	适用 10A 国际插头
B2404	6L	380W	220-240V~	50/60HZ	适用 10A 国际插头

B2405 / B2406

镀金全翻盖双头宴会汤炉

> Oblong Soup Station
> Gilt / Chrome Legs



B2405



B2406

型号	容量	额定功率	额定电压	额定频率	
B2405	4.6L*2	380W	220-240V~	50/60HZ	适用 10A 国际插头
B2406	4.6L*2	380W	220-240V~	50/60HZ	适用 10A 国际插头

B2407 / B2408

镀金全翻盖球形宴会汤炉

> Round Soup Station
> Gilt / Chrome Legs



B2407



B2408

型号	容量	额定功率	额定电压	额定频率	
B2407	4.6L	380W	220-240V~	50/60HZ	适用 10A 国际插头
B2408	4.6L	380W	220-240V~	50/60HZ	适用 10A 国际插头

B68 SERIES (系列)

标配酒精炉可选配电热板

B6801-1 / B6801-2

B6801G-1 / B6801G-2

镀金全翻盖单 / 双格宴会餐炉

> Oblong Chafing Dish
> Gilt / Chrome Legs



B6801-1 / B6801-2



B6801G-1 / B6801G-2

型号	容量	额定功率	额定电压	额定频率	
B6801-1 (单格 Single)	8.3L	380W	220-240V~	50/60HZ	适用 10A 国际插头
B6801-2 (双格 Double)	4L*2	380W	220-240V~	50/60HZ	适用 10A 国际插头
B6801G-1 (单格 Single)	8.3L	380W	220-240V~	50/60HZ	适用 10A 国际插头
B6801G-2 (双格 Double)	4L*2	380W	220-240V~	50/60HZ	适用 10A 国际插头

B6805 / B6805G

镀金全翻盖双头宴会汤炉

> Oblong Soup Station
> Gilt / Chrome Legs



B6805



B6805G

型号	容量	额定功率	额定电压	额定频率	
B6805	4.6L*2	380W	220-240V~	50/60HZ	适用 10A 国际插头
B6805G	4.6L*2	380W	220-240V~	50/60HZ	适用 10A 国际插头

B6803 / B6803G

镀金全翻盖球形宴会餐炉

> Round Chafing Dish
> Gilt / Chrome Legs



型号	容量	额定功率	额定电压	额定频率	
B6803 / B6803G	6L	380W	220-240V~	50/60HZ	适用 10A 国际插头

B6807 / B6807G

镀金全翻盖球形宴会汤炉

> Round Soup Station
> Gilt / Chrome Legs



型号	容量	额定功率	额定电压	额定频率	
B6807 / B6807G	4.6L	380W	220-240V~	50/60HZ	适用 10A 国际插头

K6801-1

镀金全翻盖宴会餐炉

> Chafing Dish
> All Gold Plated



型号	容量	额定功率	额定电压	额定频率	
K6801-1	8.3L	380W	220-240V~	50/60HZ	适用 10A 国际插头

K6803

镀金全翻盖宴会餐炉

> Round Chafing Dish
> All Gold Plated



型号	容量	额定功率	额定电压	额定频率	
K6803	6L	380W	220-240V~	50/60HZ	适用 10A 国际插头

B67 SERIES (系列)

标配酒精炉可选配电热板

B6701-1 / B6701-2

B6702-1 / B6702-2

镀金 / 全钢全翻盖单 / 双格宴会餐炉

> Oblong Chafing Dish
> Gilt / s.s / Chrome Legs



B6701-1 / B6701-2



B6701G-1 / B6701G-2



B6702-1 / B6702-2

型号	容量	额定功率	额定电压	额定频率	
B6701-1 (单格 Single)	8.3L	380W	220-240V~	50/60HZ	适用 10A 国际插头
B6701-2 (双格 Double)	4L*2	380W	220-240V~	50/60HZ	适用 10A 国际插头
B6701G-1 (单格 Single)	8.3L	380W	220-240V~	50/60HZ	适用 10A 国际插头
B6701G-2 (双格 Double)	4L*2	380W	220-240V~	50/60HZ	适用 10A 国际插头
B6702-1 (单格 Single)	8.3L	380W	220-240V~	50/60HZ	适用 10A 国际插头
B6702-2 (双格 Double)	4L*2	380W	220-240V~	50/60HZ	适用 10A 国际插头

B6703 / B6704

镀金 / 全钢全翻盖球形宴会餐炉

> Round Chafing Dish
> Gilt / s.s / Chrome Legs



B6703



B6703G



B6704

型号	容量	额定功率	额定电压	额定频率	
B6703	6L	380W	220-240V~	50/60HZ	适用 10A 国际插头
B6703G	6L	380W	220-240V~	50/60HZ	适用 10A 国际插头
B6704	6L	380W	220-240V~	50/60HZ	适用 10A 国际插头

B6705 / B6706

镀金全翻盖双头宴会汤炉

> Oblong Soup Station
> Gilt / s.s / Chrome Legs



B6705



B6705G



B6706

型号	容量	额定功率	额定电压	额定频率	
B6505	4.6L*2	380W	220-240V~	50/60HZ	适用 10A 国际插头
B6505G	4.6L*2	380W	220-240V~	50/60HZ	适用 10A 国际插头
B6706	4.5L*2	380W	220-240V~	50/60HZ	适用 10A 国际插头

B6707 / B6708

镀金全翻盖球形宴会汤炉

> Round Soup Station
> Gilt / s.s / Chrome Legs



B6707



B6707G



B6708

型号	容量	额定功率	额定电压	额定频率	
B6707	4.6L	380W	220-240V~	50/60HZ	适用 10A 国际插头
B6707G	4.6L	380W	220-240V~	50/60HZ	适用 10A 国际插头
B6708	4.6L	380W	220-240V~	50/60HZ	适用 10A 国际插头

B65/20/21 SERIES (系列)

标配酒精炉可选配电热板

B6501-1 / B6501-2

全钢全翻盖单 / 双格宴会餐炉

> Oblong Chafing Dish
> s.s Legs



型号	容量	额定功率	额定电压	额定频率	
B6501-1 (单格 Single)	8.3L	380W	220-240V~	50/60HZ	适用 10A 国际插头
B6501-2 (双格 Double)	4L*2	380W	220-240V~	50/60HZ	适用 10A 国际插头
2001-1 (单格 Single)	8.3L	380W	220-240V~	50/60HZ	适用 10A 国际插头
2001-2 (双格 Double)	4L*2	380W	220-240V~	50/60HZ	适用 10A 国际插头

2001-1 / 2001-2

镀金宴会餐炉

> Oblong Chafing Dish
> Gilt Legs



B6503

全钢全翻盖球形宴会餐炉

> Round Chafing Dish
> s.s Legs



型号	容量	额定功率	额定电压	额定频率	
B6503	6L	380W	220-240V~	50/60HZ	适用 10A 国际插头
2002	8.3L	380W	220-240V~	50/60HZ	适用 10A 国际插头

2002

镀金宴会餐炉

> Chafing Dish
> Gilt Legs



B6505

全钢全翻盖球形宴会汤炉

> Oblong Soup Station
> s.s Legs



型号	容量	额定功率	额定电压	额定频率	
B6505	4.6L*2	380W	220-240V~	50/60HZ	适用 10A 国际插头
2003	4.5L*2	380W	220-240V~	50/60HZ	适用 10A 国际插头

2003

镀金宴会汤炉

> Oblong Chafing Dish
> Gilt Legs



B6507

全钢全翻盖球形宴会汤炉

> Round Soup Station
> s.s Legs



型号	容量	额定功率	额定电压	额定频率	
B6507	4.6L	380W	220-240V~	50/60HZ	适用 10A 国际插头
2101	8L	380W	220-240V~	50/60HZ	适用 10A 国际插头

2101

全钢宴会餐炉

> Chafing Dish



21/22/23/24 SERIES (系列)

标配酒精炉可选配电热板

2102 全钢宴会餐炉

> Chafing Dish



型号	容量	额定功率	额定电压	额定频率	
2102	4L*2	380W	220-240V~	50/60HZ	适用 10A 国际插头
2203	4.5L*2	380W	220-240V~	50/60HZ	适用 10A 国际插头

2203 宴会汤炉

> Soup Station

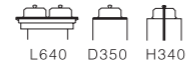

2103 全钢宴会汤炉

> Soup Station

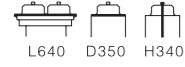

型号	容量	额定功率	额定电压	额定频率	
2103	4.5L*2	380W	220-240V~	50/60HZ	适用 10A 国际插头
2301	4.6L	180W	220-240V~	50/60HZ	适用 DB-180A 电热板 适用 10A 国际插头

2301 宴会餐炉

> Chafing Dish



2201 宴会餐炉

> Chafing Dish



型号	容量	额定功率	额定电压	额定频率	
2201	4L*2	380W	220-240V~	50/60HZ	适用 10A 国际插头
2401	8.3L	380W	220-240V~	50/60HZ	适用 10A 国际插头

2401 镀金宴会餐炉

> Rectangle Chafing Dish
> Gilt Legs



2202 宴会餐炉

> Chafing Dish



型号	容量	额定功率	额定电压	额定频率	
2202	8.3L	380W	220-240V~	50/60HZ	适用 10A 国际插头
2405	4.5L*2	380W	220-240V~	50/60HZ	适用 10A 国际插头

2405 镀金宴会汤炉

> Rectangle Soup Station
> Gilt Legs



A7905 简易餐炉

> Eco Chafing Dish



型号	容量	额定功率	额定电压	额定频率	
A7905	8.3L	380W	220-240V~	50/60HZ	适用 10A 国际插头
A9801	8.3L	380W	220-240V~	50/60HZ	适用 10A 国际插头

A9801 半翻盖餐炉

> Half Roll-top Chafing Dish



24/25/26 SERIES (系列)

标配酒精炉可选配电热板

2406 全钢宴会汤炉

> Rectangle Soup Station
> Chrome Legs



型号	容量	额定功率	额定电压	额定频率	
2406	4.5L*2	380W	220-240V~	50/60HZ	适用 10A 国际插头
2501	8.3L	380W	220-240V~	50/60HZ	适用 10A 国际插头

2501 宴会餐炉

> Chafing Dish



2402 全钢宴会餐炉

> Round Chafing Dish
> Chrome Legs



型号	容量	额定功率	额定电压	额定频率	
2402	8.3L	380W	220-240V~	50/60HZ	适用 10A 国际插头
2502	8.3L	380W	220-240V~	50/60HZ	适用 10A 国际插头

2502 宴会餐炉

> Chafing Dish



2403 镀金宴会餐炉

> Round Dish
> Gilt Legs



型号	容量	额定功率	额定电压	额定频率	
2403	6L	380W	220-240V~	50/60HZ	适用 10A 国际插头
2503	6L	380W	220-240V~	50/60HZ	适用 10A 国际插头

2503 宴会汤炉

> Soup Station

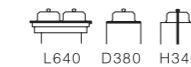

2404 全钢宴会餐炉

> Round Dish
> Chrome Legs



型号	容量	额定功率	额定电压	额定频率	
2404	7L	380W	220-240V~	50/60HZ	适用 10A 国际插头
2603	5L	180W	220-240V~	50/60HZ	适用 10A 国际插头 配专用 DB-180A 电热板

2603 宴会餐炉

> Chafing Dish



2407 全钢宴会餐炉

> Round Dish
> Gilt Legs



型号	容量	额定功率	额定电压	额定频率	
2407	4.5L	380W	220-240V~	50/60HZ	适用 10A 国际插头
2408	4.5L	180W	220-240V~	50/60HZ	适用 10A 国际插头

2408 宴会餐炉

> Round Dish
> Chrome Legs



26/27 SERIES (系列)

标配酒精炉可选配电热板

2604 宴会汤炉

> Soup Station

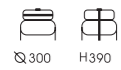

型号	容量	额定功率	额定电压	额定频率	
2604	10L	180W	220-240V~	50/60HZ	适用 10A 国际插头
2703	7L	380W	220-240V~	50/60HZ	适用 10A 国际插头



2703 宴会餐炉

> Round Chafing Dish



2605 宴会汤炉

> Soup Station



型号	容量	额定功率	额定电压	额定频率	
2605	10L	180W	220-240V~	50/60HZ	适用 10A 国际插头
2704	7L	380W	220-240V~	50/60HZ	适用 10A 国际插头



2704 嵌入式宴会餐炉

> Round Built-in Chafing Dish



2701 宴会餐炉

> Rectangle Chafing Dish



型号	容量	额定功率	额定电压	额定频率	
2701	4L*2	380W	220-240V~	50/60HZ	适用 10A 国际插头
2705	8.3L	380W	220-240V~	50/60HZ	适用 10A 国际插头



2705 嵌入式宴会餐炉

> 1/1 GN built-in Chafing Dish



2702 全钢宴会汤炉

> Rectangle Soup Station



型号	容量	额定功率	额定电压	额定频率	
2702	4L*2	380W	220-240V~	50/60HZ	适用 10A 国际插头
2801	5L	180W	220-240V~	50/60HZ	适用 10A 国际插头 适合 DB-180A 专用电热板



2801 嵌入式宴会餐炉

> Chafing Dish



2802 宴会汤炉

> Soup Station W
> Chrome Legs



型号	容量	额定功率	额定电压	额定频率	
2802	10L	180W	220-240V~	50/60HZ	适用 10A 国际插头



C24/68 SERIES (系列)

标配酒精炉可选配电热板

C2401-1 / C2401-2

C6801-1 / C6801-2

镀金全翻盖单格 / 双格宴会餐炉

> Square Chafing Dish
> Gilt Legs



型号	容量	额定功率	额定电压	额定频率	
C2401-1 (单格 Single)	4.8L	280W	220-240V~	50/60HZ	适用 10A 国际插头
C2401-2 (双格 Double)	2.1L*2	280W	220-240V~	50/60HZ	适用 10A 国际插头
C6801-1 (单格 Single)	4.8L	280W	220-240V~	50/60HZ	适用 10A 国际插头
C6801-2 (双格 Double)	2.1L*2	280W	220-240V~	50/60HZ	适用 10A 国际插头



C2409 / C6809

镀金全翻盖球形宴会餐炉

> Round Chafing Dish
> Gilt Legs



型号	容量	额定功率	额定电压	额定频率	
C2409	7.6L	280W	220-240V~	50/60HZ	适用 10A 国际插头
C6809(原 6809)	7.6L	280W	220-240V~	50/60HZ	适合 DB-280A 专用电热板



C2405 / C6805

镀金全翻盖单头宴会汤炉

> Square Soup Station
> Gilt Legs



型号	容量	额定功率	额定电压	额定频率	
C2405	4.6L	280W	220-240V~	50/60HZ	适用 10A 国际插头
C6805	4.6L	280W	220-240V~	50/60HZ	适合 DB-280A 专用电热板



C2409T / C6809T

镀金全翻盖球形宴会汤炉

> Round Soup Station
> Gilt Legs



型号	容量	额定功率	额定电压	额定频率	
C2409T(原 B2409T)	4.6L	250W	220-240V~	50/60HZ	适用 10A 国际插头
C6809T(原 B6809T)	4.6L	250W	220-240V~	50/60HZ	适合 DB-280A 专用电热板



C67/65 SERIES (系列)

标配酒精炉可选配电热板

C6701-1 / C6701-2

C6702-1 / C6702-2

镀金 / 全钢全翻盖单 / 双格宴会餐炉

> Square Chafing Dish
> Gilt / s.s Legs



型号	容量	额定功率	额定电压	额定频率	
C6701-1 (单格 Single)	4.8L	280W	220-240V~	50/60HZ	
C6701-2 (双格 Double)	2.1L*2	280W	220-240V~	50/60HZ	适用 10A 国际插头
C6702-1 (单格 Single)	4.8L	280W	220-240V~	50/60HZ	适合 DB-280A 专用电热板
C6702-2 (双格 Double)	2.1L*2	280W	220-240V~	50/60HZ	



C6701-1 / C6701-2



C6702-1 / C6702-2

C6709 / C6710

镀金 / 全钢全翻盖球形宴会餐炉

> Round Chafing Dish
> Gilt / s.s Legs



型号	容量	额定功率	额定电压	额定频率	
C6709(原 B6709)	7.6L	280W	220-240V~	50/60HZ	适用 10A 国际插头
C6710(原 B6710)	7.6L	280W	220-240V~	50/60HZ	适合 DB-280A 专用电热板



C6709



C6710

C6705 / C6706

镀金 / 全钢全翻盖单头宴会汤炉

> Square Soup Station
> Gilt / s.s Legs



型号	容量	额定功率	额定电压	额定频率	
C6705	4.6L	280W	220-240V~	50/60HZ	适用 10A 国际插头
C6706	4.6L	280W	220-240V~	50/60HZ	适合 DB-280A 专用电热板



C6705



C6706

C6709T / C6710T

镀金 / 全钢全翻盖球形宴会汤炉

> Round Soup Station
> Gilt / s.s Legs



型号	容量	额定功率	额定电压	额定频率	
C6709T(原 B6709T)	4.6L	280W	220-240V~	50/60HZ	适用 10A 国际插头
C6710T(原 B6710T)	4.6L	280W	220-240V~	50/60HZ	适合 DB-280A 专用电热板



C6709T



C6710T

W SERIES (系列)

Use natural wood materials more heat insulation, not easy to burn.
The temperature can be adjusted from normal temperature to boiling. integrated design of wood and stainless steel

使用天然实木材料更加隔热、不易烫
温度可在常温到沸点任意调节
木材与不锈钢结合的一体化设计

The appearance of the personalized design of convex and concave
外观采用凸与凹的个性设计

Notch design for convenient
方便取锅的缺口设计

Collocation thermostat
electric warmer inside
内有搭配高温电热板

Unique design of cooling hole
独特的散热孔设计

Antiskid mat provided
on the bottom
底部有防滑脚垫



W104

木制餐炉

> Oblong Chafing Dish with Glass Lid
> Electric Heater Wooden Stand 8.3L



W102

木制餐炉

> Square Chafing Dish with Glass Lid
> Electric Heater Wooden Stand 4.8L



W101

木制餐炉

> Oblong Chafing Dish with Glass Lid
> Electric Heater Wooden Stand 6.0L



W2850

木制曼哈顿

> Wooden Buffet Stand



W2830

木制曼哈顿

> Wooden Buffet Stand



CH2201

冷鲜宴会餐炉

> Oblong Chafing Dish with Coldice pack
Display



可持续保温
6小时

J SERIES (系列)

Adoption of special technology,
Keep the lid permanently sealed.

可调节旋钮
采用特殊技术，
让盖子保持持久密封。

Special show window use the Duont's
hightech matterial, Original creation
making craft, no steam and greasy stain.

可视窗
采用杜邦公司高科技材料，独创制作
工艺，可视窗防雾化，防油腻。

The whole body is made of 304
stainless steel.

材料
全身采用 304 不锈钢精致打造。



J301PG / J305PG 宴会餐炉

> Round Steel Lid Vision Induction
Chafing dish, W/ss insert



J301RG / J305RG 宴会餐炉

> Round Steel Lid Vision Induction
Chafing dish, W/ss insert

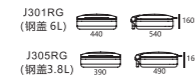

J301WG / J305WG 宴会餐炉

> Round Steel Lid Vision Induction
Chafing dish, W/ss insert

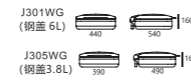

J301P / J305P 宴会餐炉

> Round Glass Lid Vision Induction
Chafing dish, W/ss insert

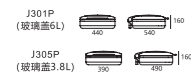

J301R / J305R 宴会餐炉

> Round Glass Lid Vision Induction
Chafing dish, W/ss insert



J301W / J305W 宴会餐炉

> Round Glass Lid Vision Induction
Chafing dish, W/ss insert

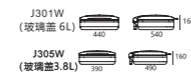

J302PG / J306PG J302RG / J306RG J302WG / J306WG 宴会餐炉

> Square Steel Lid Vision Induction
Chafing dish, w/SS insert



J302P / J306P J302R / J306R J302W / J306W 宴会餐炉

> Square Steel Lid Vision Induction
Chafing dish, w/SS insert



标配酒精炉可选配电热板

J701PG / J705PG J701RG / J705RG J701WG / J705WG 宴会餐炉

> Round Steel Lid Vision Induction
Chafing dish, w/ss insert, With
stand



型号	容量	额定功率	额定电压	额定频率	
J701PG/J705PG	6L	350W	220-240V~	50/60HZ	适用 10A 国际插头 适合 DB-500RJ 专用电热板 最高温度 ≤ 100°C
J701RG/J705RG	6L	350W	220-240V~	50/60HZ	
J701WG/J705WG	6L	350W	220-240V~	50/60HZ	

J701P / J705P J701R / J705R J701W / J705W 宴会餐炉

> Round Glass Lid Vision Induction
Chafing dish, w/ss insert, With
stand



型号	容量	额定功率	额定电压	额定频率	
J701P/J705P	6L	500W	220-240V~	50/60HZ	适用 10A 国际插头 适合 DB-500RJ 专用电热板 最高温度 ≤ 100°C
J701R/J705R	6L	500W	220-240V~	50/60HZ	
J701W/J705W	6L	500W	220-240V~	50/60HZ	

J SERIES (系列)

标配酒精炉可选配电热板

J702PG / J706PG
J702RG / J706RG
J702WG / J706WG
宴会餐炉

> Square Steel Lid Vision Induction
Chafing dish, w/ss insert, With
stand



型号	容量	额定功率	额定电压	额定频率	
J702PG/J706PG	6L	500W	220-240V~	50/60HZ	适用 10A 国际插头
J702RG/J706RG	6L	500W	220-240V~	50/60HZ	适合 DB-500RJ 专用电热板
J702WG/J706WG	6L	500W	220-240V~	50/60HZ	最高温度 ≤ 100°C

J702P / J706P
J702R / J706R
J702W / J706W
宴会餐炉

> Square Glass Lid Vision Induction
Chafing dish, w/ss insert, With
stand



型号	容量	额定功率	额定电压	额定频率	
J702P/J706P	3.8L	350W	220-240V~	50/60HZ	适用 10A 国际插头
J706R/J706R	3.8L	350W	220-240V~	50/60HZ	适合 DB-350RJ 专用电热板
J706W/J706W	3.8L	350W	220-240V~	50/60HZ	最高温度 ≤ 100°C

J401PG / J405PG
J401RG / J405RG
J401WG / J405WG
宴会餐炉

> Round Steel Lid Vision Induction
Chafing dish, w/ss insert, With
stand and fuel holder



型号	容量	额定功率	额定电压	额定频率	
J401PG/J405PG	6L	500W	220-240V~	50/60HZ	适用 10A 国际插头
J401RG/J405RG	6L	500W	220-240V~	50/60HZ	适合 DB-500RJ 专用电热板
J401WG/J405WG	6L	500W	220-240V~	50/60HZ	最高温度 ≤ 100°C

J401P/J405P
J401R/J405R
J401W/J405W
宴会餐炉

> Round Glass Lid Vision Induction
Chafing dish, w/ss insert, With
stand and fuel holder



型号	容量	额定功率	额定电压	额定频率	
J401P/J405P	3.8L	350W	220-240V~	50/60HZ	适用 10A 国际插头
J401R/J405R	3.8L	350W	220-240V~	50/60HZ	适合 DB-500RJ 专用电热板
J401W/J405W	3.8L	350W	220-240V~	50/60HZ	最高温度 ≤ 100°C

J SERIES (系列)

标配酒精炉可选配电热板

J402PG / J406PG
J402RG / J406RG
J402WG / J406WG
宴会餐炉

> Square Steel Lid Vision Induction
Chafing dish, w/ss insert, With
stand and fuel holder



型号	容量	额定功率	额定电压	额定频率	
J402PG/J406PG	6LL	500W	220-240V~	50/60HZ	适用 10A 国际插头
J402RG/J406RG	6LL	500W	220-240V~	50/60HZ	适合 DB-500RJ 专用电热板
J402WG/J406WG	6LL	500W	220-240V~	50/60HZ	最高温度 ≤ 100°C

J402P / J406P
J402R / J406R
J402W / J406W
宴会餐炉

> Square Glass Lid Vision Induction
Chafing dish, w/ss insert, With
stand and fuel holder

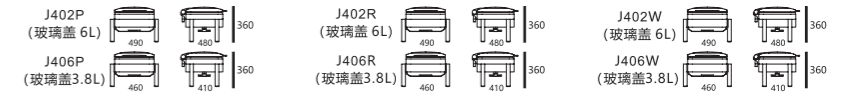

型号	容量	额定功率	额定电压	额定频率	
J402P/J406P	6LL	350W	220-240V~	50/60HZ	适用 10A 国际插头
J402R/J406R	6LL	350W	220-240V~	50/60HZ	适合 DB-350RJ 专用电热板
J402W/J406W	6LL	350W	220-240V~	50/60HZ	最高温度 ≤ 100°C

C70P / C80P
C70R / C80R
C70W / C80W
宴会餐炉

> Stand for Round 30cm/38cm
Chafing Dish

C90P / C100P
C90R / C100R
C90W / C100W
宴会餐炉

> Stand for Mini Square 1/2 Chafing Dish
> Stand for Square GN2/3 Chafing Dish



J SERIES (系列)

标配酒精炉可选配电热板

J701B / J701BG / J705B / J705BG

圆形餐炉玻璃盖 / 钢盖

> Round Glass Lid Vision Induction
Chafing dish, w/ss insert, With
stand



型号	容量	额定功率	额定电压	额定频率	
J701B/J701BG	6L	500W	220-240V~	50/60HZ	适用 10A 国际插头 适合 DB-500RJ/350RJ 专用电热板 最高温度 ≤ 100°C
J705B/J705BG	3.8L	350W	220-240V~	50/60HZ	

J702B / J702BG / J706B / J706BG

方形餐炉玻璃盖 / 钢盖

> Square Glass Lid Vision Induction
Chafing dish, w/ss insert, With
stand



型号	容量	额定功率	额定电压	额定频率	
J702B/J702BG	6L	500W	220-240V~	50/60HZ	适用 10A 国际插头 适合 DB-500RJ/350RJ 专用电热板 最高温度 ≤ 100°C
J706B/J706BG	3.8L	350W	220-240V~	50/60HZ	

J701S / J701SG / J705S / J705SG

圆形餐炉玻璃盖 / 钢盖

> Round Glass Lid Vision Induction
Chafing dish, w/ss insert, With
stand



型号	容量	额定功率	额定电压	额定频率	
J701S/J701SG	6L	500W	220-240V~	50/60HZ	适用 10A 国际插头 适合 DB-500RJ/350RJ 专用电热板 最高温度 ≤ 100°C
J705S/J705SG	3.8L	350W	220-240V~	50/60HZ	

J702S / J702SG / J706S / J706SG

方形餐炉玻璃盖 / 钢盖

> Square Glass Lid Vision Induction
Chafing dish, w/ss insert, With
stand



型号	容量	额定功率	额定电压	额定频率	
J702S/J702SG	6L	500W	220-240V~	50/60HZ	适用 10A 国际插头 适合 DB-500RJ/350RJ 专用电热板 最高温度 ≤ 100°C
J706S/J706SG	3.8L	350W	220-240V~	50/60HZ	

J SERIES (系列)

标配酒精炉可选配电热板

J401B / J401BG / J405B / J405BG

圆形餐炉玻璃盖 / 钢盖

> Round Glass Lid Vision Induction
Chafing dish, w/ss insert, With
stand and fuel holder

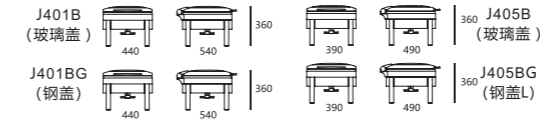

型号	容量	额定功率	额定电压	额定频率	
J401B/J401BG	6L	500W	220-240V~	50/60HZ	适用 10A 国际插头 适合 DB-500RJ/350RJ 专用电热板 最高温度 ≤ 100°C
J405B/J405BG	3.8L	350W	220-240V~	50/60HZ	

J402B / J402BG / J406B / J406BG

方形餐炉玻璃盖 / 钢盖

> Square Glass Lid Vision Induction
Chafing dish, w/ss insert, With
stand and fuel holder

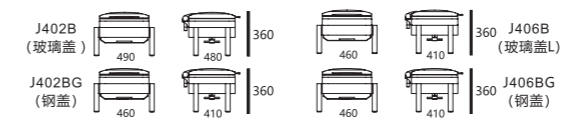

型号	容量	额定功率	额定电压	额定频率	
J402B/J402BG	6L	500W	220-240V~	50/60HZ	适用 10A 国际插头 适合 DB-500RJ/350RJ 专用电热板 最高温度 ≤ 100°C
J406B/J406BG	3.8L	350W	220-240V~	50/60HZ	

J401S / J401SG / J405S / J405SG

圆形餐炉玻璃盖 / 钢盖

> Round Glass Lid Vision Induction
Chafing dish, w/ss insert, With
stand and fuel holder



型号	容量	额定功率	额定电压	额定频率	
J401S/J401SG	6L	500W	220-240V~	50/60HZ	适用 10A 国际插头 适合 DB-500RJ/350RJ 专用电热板 最高温度 ≤ 100°C
J405S/J405SG	3.8L	350W	220-240V~	50/60HZ	

J402S / J402SG / J406S / J406SG

方形餐炉玻璃盖 / 钢盖

> Square Glass Lid Vision Induction
Chafing dish, w/ss insert, With
stand and fuel holder



型号	容量	额定功率	额定电压	额定频率	
J402S/J402SG	6L	500W	220-240V~	50/60HZ	适用 10A 国际插头 适合 DB-500RJ/350RJ 专用电热板 最高温度 ≤ 100°C
J406S/J406SG	3.8L	350W	220-240V~	50/60HZ	

J SERIES (系列)

J401GCG / J405GCG

J402GCG / J406GCG

镀金圆形 / 方形餐炉

> Round / Square steel Lid Vision Induction Chafing dish, w/ss insert

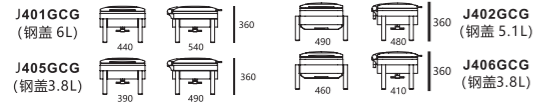

标配酒精炉可选配电热板



J401GCG/J405GCG

J402GCG/J406GCG

型号	容量	额定功率	额定电压	额定频率	
J401GCG/J405GCG	6L/3.8L	500W	220-240V~	50/60HZ	适用 10A 国际插头 适合 DB-500RJ/350RJ 专用电热板 最高温度 ≤ 100°C
J402GCG/J406GCG	5.1L/3.8L	350W	220-240V~	50/60HZ	

J301B / J305B / J301BG / J305BG

圆形餐炉玻璃盖 / 钢盖

> Round Glass Lid Vision Induction Chafing dish, w/ss insert

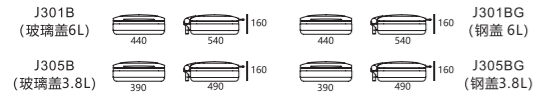

J301B/J305B

J301BG/J305BG

J302B / J306B / J302BG / J306BG

方形餐炉玻璃盖 / 钢盖

> Square Glass Lid Vision Induction Chafing dish, w/ss insert

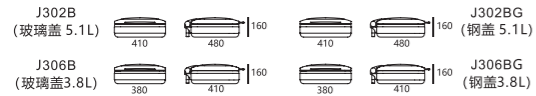

J302B/J306B

J302BG/J306BG

J301S / J305S / J301SG / J305SG

圆形餐炉玻璃盖 / 钢盖

> Round Glass Lid Vision Induction Chafing dish, w/ss insert

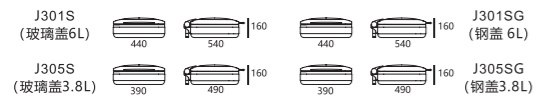

J301S/J305S

J301SG/J305SG

J302S / J306S / J302SG / J306SG

方形餐炉玻璃盖 / 钢盖

> Square Glass Lid Vision Induction Chafing dish, w/ss insert

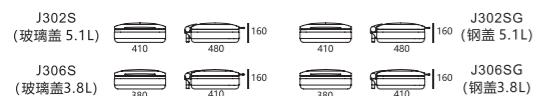

J302S/J306S

J302SG/J306SG

J SERIES (系列)

J301GCG / J305GCG

宴会餐炉

> Round Steel Lid Vision Induction Chafing dish, w/ss insert

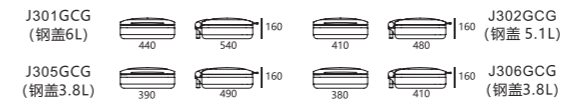

J304K / J304KG

镀金方形餐炉

> Oblong GN1/1 Glass Lid Vision Induction Chafing dish, w/ss insert



C1530B / C1538B

圆形餐炉框架

> Stand for Round 38cm/30cm Chafing Dish



C1523B / C1512B

方形餐炉框架

> Stand for Square GN2/3 GN1/2 Chafing Dish

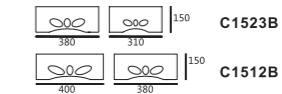

C1530S / C1538S

圆形餐炉框架

> Stand for Round 38cm/30cm Chafing Dish



C1523S / C1512S

方形餐炉框架

> Stand for Square GN2/3 GN1/2 Chafing Dish

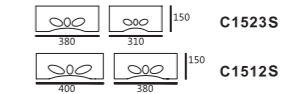

J301K / J301KG / J305K / J305KG

圆形 / 方形餐炉框架

> Round Glass Lid Vision Induction Chafing dish, w/ss insert



J SERIES (系列)

标配酒精炉可选配电热板

J302K / J302KG / J306K / J306KG

方形餐炉玻璃盖 / 钢盖

> Square Glass/s.s Lid Vision Induction Chafing dish, w/ss insert

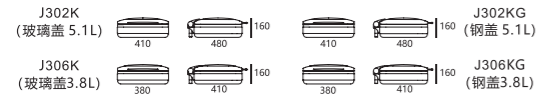

J302K/J306K

J302KG/J306KG

J401K / J401KG / J405K / J405KG

镀金圆形 / 方形餐炉

> Round Glass/s.s Lid Vision Induction Chafing dish, w/ss insert, with stand and fuel holder

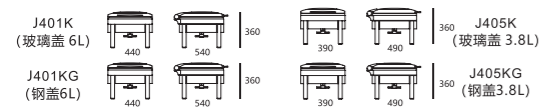

J401K/J405K

J401KG/J405KG

型号	容量	额定功率	额定电压	额定频率	
J401K/J405KG	6L	500W	220-240V~	50/60HZ	适用 10A 国际插头
J401KG/J405KG	3.8L	350W	220-240V~	50/60HZ	适合 DB-500RJ 专用电热板 最高温度 ≤ 100° C

J402K / J402KG / J406K / J406KG

镀金圆形 / 方形餐炉

> Square Glass/s.s Lid Vision Induction Chafing dish, w/ss insert, with stand and fuel holder

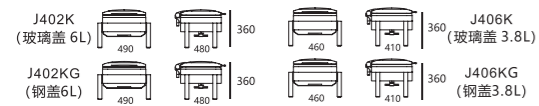

J402K/J406K

J406KG/J406KG

型号	容量	额定功率	额定电压	额定频率	
J402K/J402KG	6L	500W	220-240V~	50/60HZ	适用 10A 国际插头
J406KG/J406KG	3.8L	350W	220-240V~	50/60HZ	适合 DB-350 专用电热板 最高温度 ≤ 100° C

J404K / J404KG

镀金圆形 / 方形餐炉

> Rectangle Glass/s.s Lid Vision Induction Chafing dish, w/ss insert



J404K

J404KG

型号	容量	额定功率	额定电压	额定频率	
J404K	8.3L	500W	220-240V~	50/60HZ	适用 10A 国际插头
J404KG	8.3L	500W	220-240V~	50/60HZ	适合 DB-500 专用电热板

J SERIES (系列)

C70B / C80B

圆形餐炉框架

> Stand for Round 30cm/38cm Chafing Dish



C90B / C100B

圆形餐炉框架

> Stand for Mini Square GN 1/2 Chafing Dish
> Stand for Square GN 2/3 Chafing Dish



C70S / C80S

圆形餐炉框架

> Stand for Round 30cm/38cm Chafing Dish



C90S / C100S

方形餐炉框架

> Stand for Mini Square GN 1/2 Chafing Dish
> Stand for Square GN 2/3 Chafing Dish

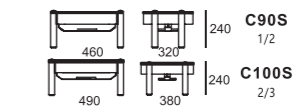

C70G / C80G

圆形餐炉框架

> Stand for Round 30cm/38cm Chafing Dish



C90G / C100G

方形餐炉框架

> Stand for Mini Square GN 1/2 Chafing Dish
> Stand for Square GN 2/3 Chafing Dish



C104B / C104G / C104S

1/1 方形餐炉框架

> Stand for Oblong GN 1/1 Chafing Dish

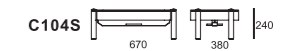

J SERIES (系列)

J301 / J305

宴会餐炉

> Round Glass Lid Vision Chafing dish, w/ss insert

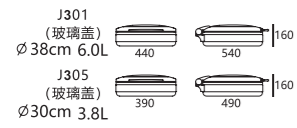

J301G / J305G

宴会餐炉

> Round Steel Lid Vision Chafing dish, w/ss insert

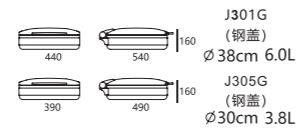

J302 / J306

宴会餐炉

> Square Glass Lid Vision Chafing dish, w/ss insert

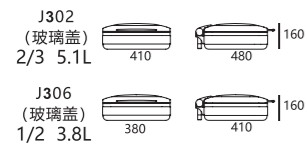

J302G / J306G

宴会餐炉

> Square Steel Lid Vision Chafing dish, w/ss insert

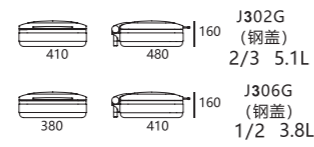

J303

宴会汤炉

> Round Glass Lid Vision Soup Station dish, w/ss insert

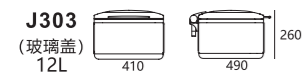

J303G

宴会汤炉

> Round Steel Lid Vision Soup Station dish, w/ss insert



J304

宴会餐炉

> Oblong Glass Lid Vision Chafing dish, w/ss insert

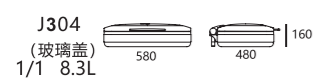

J304G

宴会餐炉

> Oblong Steel Lid Vision Chafing dish, w/ss insert

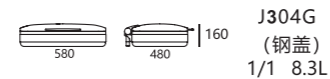

J SERIES (系列)

标配酒精炉可选配电热板

J401 / J401G / J405 / J405G

宴会餐炉

> Round Glass/Steel Lid Vision Chafing dish w/ss insert, With Stand and fuel holder

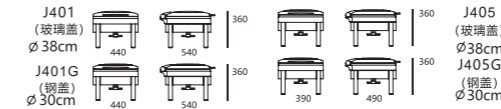

型号	容量	额定功率	额定电压	额定频率	
J401/J401G	6L	500W	220-240V~	50/60HZ	适用 10A 国际插头 适合 DB-500RJ/350RJ 专用电热板 最高温度 ≤ 100°C
J405/J405G	4L	350W	220-240V~	50/60HZ	

J402 / J402G / J406 / J406G

宴会餐炉

> Square Glass/Steel Lid Vision Chafing dish w/ss insert, With Stand and fuel holder

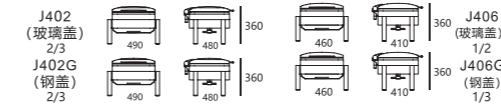

型号	容量	额定功率	额定电压	额定频率	
J402/J402G	5.1L	500W	220-240V~	50/60HZ	适用 10A 国际插头 适合 DB-500RJ/350RJ 专用电热板 最高温度 ≤ 100°C
J406/J406G	3.8L	350W	220-240V~	50/60HZ	

J403 / J403G

宴会汤炉

> Round Glass/Steel Lid Vision Soup Station dish w/ss insert, With Stand and fuel holder



型号	容量	额定功率	额定电压	额定频率	
J403	12L	350W	220-240V~	50/60HZ	适用 10A 国际插头 适合 DB-500RJ/350RJ 专用电热板
J403G	12L	350W	220-240V~	50/60HZ	

J404 / J404G

宴会餐炉

> Oblong Glass/Steel Lid Vision Chafing dish w/ss insert, With Stand and fuel holder



型号	容量	额定功率	额定电压	额定频率	
J404	8.3L	500W	220-240V~	50/60HZ	适用 10A 国际插头 适合 DB-500RJ/350RJ 专用电热板
J404G	8.3L	500W	220-240V~	50/60HZ	

J SERIES (系列)

标配酒精炉可选配电热板

J601 / J601G

宴会餐炉

> Round Glass/Steel Lid Chafing dish
> 38cm s/s food insert



型号	容量	额定功率	额定电压	额定频率	
J601	6L	500W	220-240V~	50/60HZ	适用 10A 国际插头
J601G	6L	500W	220-240V~	50/60HZ	适合 DB-500RJ 专用电热板

J602 / J602G

宴会餐炉

> Square Glass/Steel Lid Chafing dish
> 2/3 s/s food insert



型号	容量	额定功率	额定电压	额定频率	
J602	5.1L	500W	220-240V~	50/60HZ	适用 10A 国际插头
J602G	5.1L	500W	220-240V~	50/60HZ	适合 DB-500RJ 专用电热板

J603 / J603G

宴会汤炉

> Round Glass/Steel Lid Soup Station

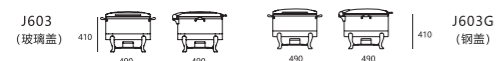

型号	容量	额定功率	额定电压	额定频率	
J603	12L	350W	220-240V~	50/60HZ	适用 10A 国际插头
J603G	12L	350W	220-240V~	50/60HZ	适合 DB-350RJ 专用电热板 最高温度 ≤ 100°C

J604 / J604G

宴会餐炉

> Oblong Glass/Steel Lid Chafing dish
> 1/1 s/s food insert



型号	容量	额定功率	额定电压	额定频率	
J604	8.3L	500W	220-240V~	50/60HZ	适用 10A 国际插头
J604G	8.3L	500W	220-240V~	50/60HZ	适合 DB-500RJ 专用电热板 最高温度 ≤ 100°C

J SERIES

标配酒精炉可选配电热板

J605 / J605G

宴会餐炉

> Round 30cm Glass/Steel Lid Vision Chafing dish
> w/SS insert, With stand and fuel holder



型号	容量	额定功率	额定电压	额定频率	
J605	4L	350W	220-240V~	50/60HZ	适用 10A 国际插头
J605G	4L	350W	220-240V~	50/60HZ	适合 DB-350RJ 专用电热板 最高温度 ≥ 100°C

J606 / J606G

宴会餐炉

> Square GN 1/2 Glass/Steel Lid Vision Chafing dish
> w/ss insert, With stand and fuel holder



型号	容量	额定功率	额定电压	额定频率	
J606	3.8L	350W	220-240V~	50/60HZ	适用 10A 国际插头
J606G	3.8L	350W	220-240V~	50/60HZ	适合 DB-350RJ 专用电热板 最高温度 ≥ 100°C

C70 / C80

圆形框架

> Stand for Round
30cm/38cm Chafing Dish



C90 / C100

方形框架

> Stand for Mini Square GN 1/2 Chafing Dish
> Stand for Square GN 2/3 Chafing Dish

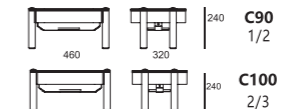

C104

长方形框架

> Stand for Oblong GN 1/1
Chafing Dish

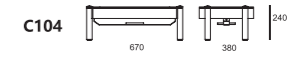

6011

12L 汤桶

> Soup Bucket 12L



DB-350RJ / DB-500RJ

调温电热板用餐炉

> Electrical Heating Plate



型号	额定电压	额定频率	
DB-350RJ	220-240V~	50/60HZ	适用 10A 国际插头
DB-500RJ	220-240V~	50/60HZ	最高温度 ≥ 100°C

CLAM CHAFING DISH

贝壳餐炉



Simple and elegant lines

手柄
线条简约、造型优美

Unique clam design, Feelings of natural flavor

餐炉盖
独特贝壳造型设计，
感触自然气息

The water vapor will back to the water pan via the water through

档水槽
全新设计贝壳系列产品，
增添档槽，防止凝水外溢。

The starfish tripod, and optional buffet induction or electric warmer.

海星脚架
锤点工艺海星脚架，可选配电磁炉或
电热板，搭配贝壳餐炉更加完美。

C101

宴会餐炉

> Clam Chafer
> Steel Lid

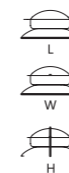

C2607

宴会餐炉

> Soup Station



型号	尺寸	额定功率	额定电压	额定频率	
C101	480*445*290	500W	220-240V~	50/60HZ	适用 10A 国际插头
C2607	480*445*290	500W	220-240V~	50/60HZ	配专用 DB-500RJ 电热板



Hinge mechanism guarantees slow down and durable open and closing.

液压转轴

使用新型的液压转轴，具有防疲劳设计，造型简洁美观；转轴的液压压力可按需在出厂前随意调节。

Increase S/S thickness, reinforce and stronger.

加厚板材

使用加厚的优质不锈钢板材，抗碰撞，不易变形。

The water vapor will back to the water pan via the water through.

挡水槽

全新改良蝶菲系列产品，增添挡水槽，防止凝水外溢。



J SERIES

标配酒精炉可选项电热板

J201 / J201G

J205 / J205G

宴会餐炉

- > Chafing dish
- > Round 38cm/30cm
- > Glass / Steel Lid



J201/J205



J201G/J205G

型号	容量	额定功率	额定电压	额定频率	
J201/J201G	6L	500W	220-240V~	50/60HZ	适用 10A 国际插头
J205/J205G	4L	350W	220-240V~	50/60HZ	适合 DB-500RJ/350RJ 专用电热板

J202 / J202G

J206 / J206G

宴会餐炉

- > Chafing dish
- > GN2/3 / GN1/2
- > Glass/Steel lid



J202/J206



J202G/J206G

型号	容量	额定功率	额定电压	额定频率	
J202/J202G	5.1L	500W	220-240V~	50/60HZ	适用 10A 国际插头
J206/J206G	3.8L	350W	220-240V~	50/60HZ	适合 DB-500RJ/350RJ 专用电热板

J203G

宴会汤炉

- > Soup Station



型号	容量	额定功率	额定电压	额定频率	
J203G	3.8L	350W	220-240V~	50/60HZ	适用 10A 国际插头
J204/J204G	3.8L	350W	220-240V~	50/60HZ	适合 DB-500RJ 专用电热板 最高温度 ≤ 100°C

J204

宴会餐炉

- > Chafing dish
- > 1/1 GN Glass Lid
- > With stand
- > 1/1 GN Glass Lid



J204G

宴会餐炉

- > Chafing dish
- > 1/1 GN Steel Lid
- > With Stand



C20 / C30 / C30-1

圆形蝶菲框

- > Round Frame



C40 / C50 / C60

方形蝶菲框

- > Square Frame

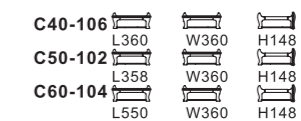

D SERIES (系列)

B101G

镀黑金碟菲餐炉

> Round Chafer 38cm with black 6L



K101G

镀黄金碟菲餐炉

> Round Chafer 38cm with gold 6L

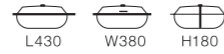

D101G-BK

圆形黑色餐炉

> Round Black Chafing Dish 38cm 6L

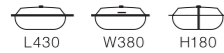

D101G-GD

圆形金色餐炉

> Round Gold Chafing Dish 38cm 6L



D102G-BK

方形黑色餐炉

> Square Black Chafing Dish 2/3 GN 5.1L



D101G-RS

圆形金色餐炉

> Round Rose Gold Chafing Dish 38cm 6L

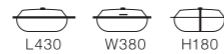

D102G-GD

方形金色餐炉

> Square Gold Chafing Dish 2/3 GN 5.1L



D102G-RS

方形玫瑰金色餐炉

> Square Rose Gold Chafing Dish 2/3 GN 5.1L



KJ1002

方形餐炉 / 玻璃盖

> Square 2/3 Glass Lid Vision Chafing Dish / Gold Color
> w/ss insert with electric heater



KJ202

宴会餐炉

> Chafing dish
> GN 2/3
> Glass / Gold Color



D SERIES (系列)

D101 / D105

蝶菲餐炉 (玻璃盖)

> Chafer / Glass Lid
> Round 38cm/30cm



D101G / D105G

蝶菲餐炉 (钢盖)

> Round Chafer 38cm/30cm
> Steel Lid

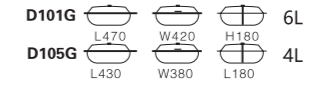

D102 / D106

碟菲餐炉

> 2/3 GN Chafer / Glass Lid
> 1/2 GN Chafer / Glass Lid



D102G / D106G

碟菲餐炉

> 2/3 GN Chafer / Steel Lid
> 1/2 GN Chafer / Steel Lid



D103

碟菲汤炉

> Soup station 10L



D104

长方形碟菲餐炉

> Induction 1/1 GN Chafer / Glass Lid 8L



D104G

长方形碟菲餐炉

> Induction 1/1 GN Chafer / Steel Lid 8L



D/J SERIES (系列)

D201G 碟菲餐炉

- > Chafer / Steel Lid
- > Electrical
- > Round 38cm

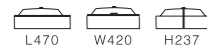

D202 碟菲餐炉

- > 2/3 GN Chafer
- > Glass Lid
- > Electrical



型号	容量	额定功率	额定电压	额定频率	
D201G	6L	280W	220-240V~	50/60HZ	配 DB-280
D202	5.1L	280W	220-240V~	50/60HZ	配 DB-280

D201 碟菲餐炉

- > Chafer / Glass Lid
- > Electrical
- > Round 38cm

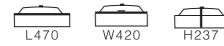

D202G 碟菲餐炉

- > 2/3 GN Chafer / Steel Lid
- > Electrical



型号	容量	额定功率	额定电压	额定频率	
D201	6L	280W	220-240V~	50/60HZ	配 DB-280
D202G	5.1L	280W	220-240V~	50/60HZ	配 DB-280

D203G 碟菲汤炉

- > Soup Station 10L



D204 碟菲汤炉

- > 1/1 GN Chafer
- > Glass / Lid
- > Electrical



型号	容量	额定功率	额定电压	额定频率	
D203G	10L	280W	220-240V~	50/60HZ	配 DB-280
D204	8.3L	280W	220-240V~	50/60HZ	配 DB-280

D204G 宴会餐炉

- > Electrical 1/1 GN Chafer
- > Steel Lid



J103G 全钢圆形汤炉 / 钢盖

- > Sout Station



型号	容量	额定功率	额定电压	额定频率	
D204	8.3L	280W	220-240V~	50/60HZ	配 DB-280
J103G	10L	280W	220-240V~	50/60HZ	适用 10A 国标插头

J SERIES (系列)

标配酒精炉可选项电热板

J101 全钢圆形餐炉 / 玻璃盖

- > Round Chafing Dish
- > s.s Leg
- > Glass Lid



J101G 全钢圆形餐炉 / 钢盖

- > Round Chafing Dish
- > s.s Leg
- > Steel Lid



型号	容量	额定功率	额定电压	额定频率	
J101	6L	380W	220-240V~	50/60HZ	配 DB-280 适用 10A 国际插头
J101G	6L	380W	220-240V~	50/60HZ	

J102 全钢方形餐炉 / 玻璃盖

- > 2/3 GN Chafer Dish
- > s.s Leg
- > Glass Lid



J102G 全钢方形餐炉 / 钢盖

- > 2/3 GN Chafer Dish
- > s.s Leg
- > Steel Lid



型号	容量	额定功率	额定电压	额定频率	
J102	5.1L	380W	220-240V~	50/60HZ	配 DB-380 适用 10A 国际插头
J102G	5.1L	380W	220-240V~	50/60HZ	

J104 全钢长方形餐炉 / 玻璃盖

- > 1/1 GN Chafing Dish
- > s.s Leg
- > Glass Lid



J104G 全钢长方形餐炉 / 钢盖

- > 1/1 GN Chafing Dish
- > s.s Leg
- > Steel Lid



型号	容量	额定功率	额定电压	额定频率	
J104	8.3L	280W	220-240V~	50/60HZ	配 DB-280 适用 10A 国际插头
J104G	8.3L	380W	220-240V~	50/60HZ	

DB-180 电热板



DB-700 调温电热板



DB-200A 加长电热板



DB-380 电热板



DB-280D 电热板



DB-280 电热板



型号	额定功率	额定电压	额定频率	
DB-180/DB-180A	180W	220-240V~	50/60HZ	
DB-700	700W	220-240V~	50/60HZ	
DB-200A	200W	220-240V~	50/60HZ	适用 10A 国际插头
DB-280/DB-280D	280W	220-240V~	50/60HZ	
DB-380	380W	220-240V~	50/60HZ	

TC SERIES (系列)



ACCORDING TO THE NEEDS OF THE COMBINATION OF SIMPLE

按需搭配 组合简易

High performance monolithic computer is used as the intelligent core control component.

采用高性能单片计算机作为智能核心控制部件。

Automatic constant temperature mode, high constant temperature accuracy, thermal insulation temperature can be adjusted from 40°C to 95°C, also can choose no thermal insulation, to meet the needs of special food.

全自动恒温模式，恒温精度高，保温温度可在 40°C 到 95°C 之间任意调节，也可选择不保温，以满足特殊食物的需要。

Digital temperature display, insulation temperature at a glance.

数码温度显示，保温温度一目了然。

Temperature memory function is designed. When the machine is turned off and restarted, the set temperature remains the same as the set temperature when the machine was turned off last time. There is no need to set it again.

设计温度记忆功能，当关机后再重新开机，则设定温度保持上一次关机时的设定温度，无需再次设定。

Automatic protection function, when the temperature sensor temperature measurement is not normal, it will automatically stop heating, and give the error code.

全自动保护功能，当温度传感器测温不正常时会自动停止加热，且给出错误代码。

Touch button, waterproof and easy to clean.

触摸按键，防水且便于清洁。

TC20

可调温双头宴会餐炉

> Double heads chafing dish with control temperature



TC10L

温控宴会汤炉

> Chafing Dish With control Temperature(Left)



型号	容量	额定功率	额定电压	额定频率	
TC20	6L*2	250W*2	220-240V~	50/60HZ	适用 10A 国标插头
TC10L	10L	250W	220-240V~	50/60HZ	适用 10A 国标插头

TC30

可调温三头宴会餐炉

> Triple heads chafing dish with control temperature

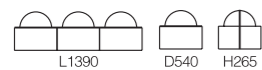

TC10R

温控宴会汤炉

> Chafing Dish With control Temperature(right)



型号	容量	额定功率	额定电压	额定频率	
TC30	6L*3	250W*2	220-240V~	50/60HZ	适用 10A 国标插头
TC10R	10L	250W	220-240V~	50/60HZ	适用 10A 国标插头

ACCESSORIES SERIES (系列)

D13

1/3 瓷盘

> 1/3 Porcelain Insert



D10

380 圆瓷盘

> Round 38cm Porcelain Insert



D10S

双格 S 形瓷盘

> Round 38cm Porcelain Insert "S" divided

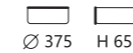

D20

双格圆瓷盘

> Round 38cm Diveded Porcelain Insert

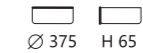

D30

2/3 方瓷盘

> GN2/3 Porcelain Insert



D60

1/1 长方形瓷盘

> 1/1 Porcelain Insert

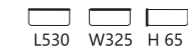

D70

300 小圆瓷盘

> Round 30cm Porcelain Insert



D70S

300 小圆 S 格瓷盘

> Round 30cm Porcelain Insert "s" divided



D70B

300 小圆直格瓷盘

> Round 30cm Porcelain Insert divided

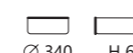

D80

1/2 小方瓷盘

> GN1/2 Porcelain Insert



ACCESSORIES SERIES (系列)

A10

380 圆铝盘

> Round 38cm aluminum plate

Ø390 H 70



A30

2/3 铝盘

> Square GN2/3 aluminum plate

L350 W325 H 65



A70

300 圆铝盘

> Round 30cm aluminum plate

Ø330 H 70



A80

1/2 方铝盘

> Square GN1/2 aluminum plate

L330 W270 H 70



D40

圆形框架

> Round Frame



D50

方形框架

> Square Frame



J2522

全钢透明盖圆形餐炉

> Round Chafing Dish
> s.s Leg
> PC Cover

L485 D485 H480



J2502

全钢透明盖方形餐炉

> Rect Chafer Dish
> s.s Leg
> PC Cover

L545 D345 H440



型号	容量	额定功率	额定电压	额定频率	
J2522	6L	380W	220-240V~	50/60HZ	配 DB-280 适用 10A 国标插头
J2502	8.3L	380W	220-240V~	50/60HZ	配 DB-280 适用 10A 国标插头

S SERIES (系列)

SD2302/20 | SD2302/40

SD2302/60

带电透明半翻盖宴会餐炉

> Roll-top Chafing Dish with Electric plate
> PC Cover

Ø500 H340 85



SD2201/20 | SD2201/40

SD2201/60

全钢透明盖方形餐炉

> Oblong Chafing Dish with Electric plate
> PC Cover

L574 B269 H276 85



型号	额定功率	额定电压	额定频率	
SD2302/20 SD2302/40 SD2302/60	250W	220-240V~	50/60HZ	配 DB-200A
SD2201/20 SD2201/40 SD2201/60	250W	220-240V~	50/60HZ	适用 10A 国标插头

S2302/20 | S2302/40

S2302/60

带电透明半翻盖宴会餐炉

> Round Half Roll-top Chafing Dish with Electric plate
> PC Cover

Ø500 H340 85



S2201/20 | S2201/40

S2201/60

全钢透明盖方形餐炉

> Oblong Chafing Dish with Electric plate
> PC Cover

L574 B269 H276 85



S2201/20J | S2201/40J

S2201/60J

透明罩宴会餐炉

> Chafing Dish

L635 B400 H400mm



SD2201/20J | SD2201/40J

SD2201/60J

透明罩宴会餐炉 (带电)

> Chafing Dish with electric plate

L635 B400 H400mm



SD2511

带电透明半翻盖宴会餐炉

S2511

透明半翻盖宴会餐炉

> Round Chafing
> Electric plate
> PC Cover

Ø550 H430 85



SD2501

带电透明半翻盖宴会餐炉

> Oblong Chafing Dish with Electric plate
> PC Cover

L600 B395 H370 85



型号	容量	额定功率	额定电压	额定频率	
SD2511	6L	250W	220-240V~	50/60HZ	配 DB-200A 适用 10A 国标插头
SD2501	8.3L	250W	220-240V~	50/60HZ	配 DB-200A 适用 10A 国标插头

CREATOR OF THE ATMOSPHERE MAKER

我们生产的不止是容器
更是品质餐饮的氛围缔造者



OTHER SERIES
其它类



STEAM OVEN SERIES (蒸炉系列)

B001 竹笼盖

> Bamboo steamer lid

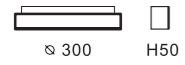

B002 竹笼底

> Bamboo steamer

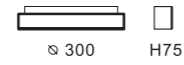

DC20 圆水盘

> Round water pan

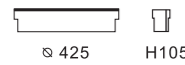

6010 圆形带孔面板

> Adaptor for steamer



有孔圆面板，可以直接把水蒸气回流到积水盘里，防止凝水外溢。

D201 (STEAM)

碟菲蒸炉

> Round steamer



型号	额定功率	额定电压	额定频率	适用 10A 国际插头
D201	700W	220-240V~	50/60HZ	适用 10A 国际插头

TC30 (STEAM)

可调温三头宴会蒸炉

> Triple Steamer



型号	额定功率	额定电压	额定频率	可调温度	适用 10A 国际插头
TC30	250WX3	220-240V~	50/60HZ	40-95°C	适用 10A 国际插头



SEAFOOD TOWER SERIES 海鲜塔系列

OTHER SERIES 其他类

WF001 红酒喷泉

> Wine Fountain

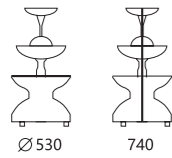

额定功率	额定电压	额定频率
1200W	220-240V~	50/60HZ 适用 10A 国际插头

3004A/3004B 四层豪华海鲜塔 / 四层全钢海鲜塔

> 4-Tiers Buffet Stand

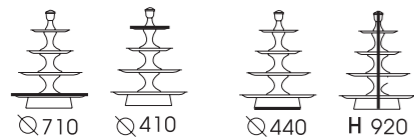

3004A 四层豪华海鲜塔



3004B 四层全钢海鲜塔



ELECTRIC FAST FOOD HOLDING FURNACE SERIES

电热快餐保温炉系列

OTHER SERIES 其他类

D7700

77 型电热快餐保温炉

> 77 Electrical Fast Food
> Warming Oven
> 1200W/100-240V



额定功率	额定电压	额定频率
1200W	220-240V~	50/60HZ 适用 10A 国际插头

D7702/ 双格

77 型电热快餐保温炉

> 77 Electrical Fast Food
> Warming Oven
> 1200W/100-240V



容量	额定功率	额定电压	额定频率
5.5LX2	1200W	220-240V~	50/60HZ 适用 10A 国际插头

D7706

77 型电热什锦炉

> 77 Electrical Fast Food
> Warming Oven
> 1200W/100-240V



额定功率	额定电压	额定频率
1200W	220-240V~	50/60HZ 适用 10A 国际插头

D7726

77 型 6 格电热快餐炉

> 77 Electrical Fast Food
> Warming Oven
> 1200W/100-240V



额定功率	额定电压	额定频率
1200W	220-240V~	50/60HZ 适用 10A 国际插头

D7701

77 型电热快餐保温炉

> 77 Electrical Fast Food
> Warming Oven
> 1200W/100-240V



容量	额定功率	额定电压	额定频率
12.5L	1200W	220-240V~	50/60HZ 适用 10A 国际插头

D7703

77 型电热快餐保温炉

> 77 Electrical Fast Food
> Warming Oven
> 1200W/100-240V



容量	额定功率	额定电压	额定频率
3.3LX3	1200W	220-240V~	50/60HZ 适用 10A 国际插头

D7720

77 型电热快餐保温汤炉

> 77 Electrical Fast Food
> Warming Oven
> 1200W/100-240V



容量	额定功率	额定电压	额定频率
7LX2	1200W	220-240V~	50/60HZ 适用 10A 国际插头

电热快餐保温炉系列

CP-40

巧克力喷泉

> Chocolate fountain/4KG

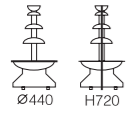

额定功率	额定电压	额定频率	适用 10A 国际插头
350W	220-240V~	50/60HZ	

**CP-60**

巧克力喷泉

> Chocolate fountain/6KG

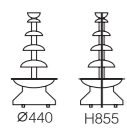

额定功率	额定电压	额定频率	适用 10A 国际插头
350W	220-240V~	50/60HZ	

**CP-80**

巧克力喷泉

> Chocolate fountain/8KG

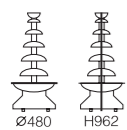

额定功率	额定电压	额定频率	适用 10A 国际插头
350W	220-240V~	50/60HZ	

**SERVICE WAGON** 餐车系列**W-0101**

双层豪华型烤牛肉车

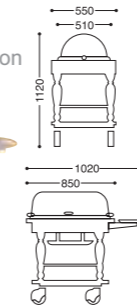
> Contiental Roast
Beef Service Wagon**W-0102**

双层豪华型烤牛肉车

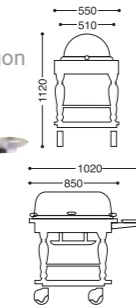
> Contiental Roast
Beef Service Wagon**W-0103**

双层豪华型烤牛肉车

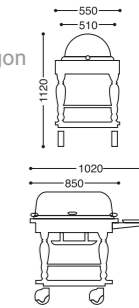
> Contiental Roast
Beef Service Wagon**CEREAL DISPENSERS** 麦片器系列**W36301**

单头麦片器 (BPA FREE)

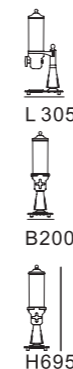
> Single Cereal Dispenser 3.6L
> Wooden Stand**W36302**

双头麦片器 (BPA FREE)

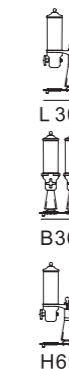
> Single Cereal Dispenser 3.6LX2
> Wooden Stand**W36303**

三头麦片器 (BPA FREE)

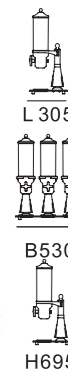
> Single Cereal Dispenser 3.6LX3
> Wooden Stand

CEREAL DISPENSERS 麦片器系列

OTHER SERIES 其他类

36301-2
单头麦片器 3.6L (BPA FREE)
> Single Cereal Dispenser 3.6L

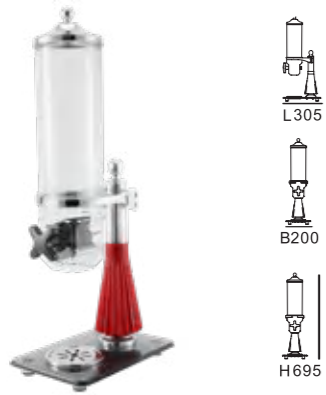

36302-2
双头麦片器 3.6LX2 (BPA FREE)
> Double Cereal Dispenser 3.6LX2

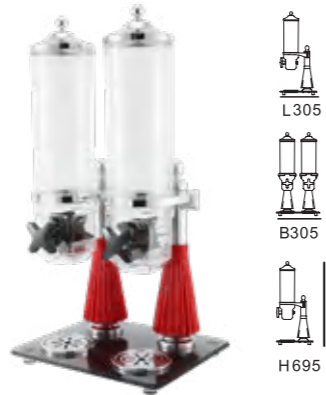

36303-2
三头麦片器 3.6LX3 (BPA FREE)
> Triple Cereal Dispenser 3.6LX3



10304
单头麦片器 10L
> Cereal Dispenser
> 10L

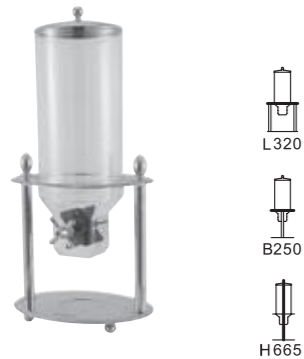

10305
双头麦片器 10LX2
> Cereal Dispenser/Double
> 10LX2



10306
三头麦片器 10LX3
> Cereal Dispenser/Triple
> 10LX3



10301
单头麦片器 10L
> Cereal Dispenser
> 10L



10302
双头麦片器 10LX2
> Cereal Dispenser/Double
> 10Lx2



JUICE DISPENSERS 果汁鼎系列

OTHER SERIES 其他类

W36401
单头果汁鼎 (BPA FREE)
> Single Juice Dispenser 3.6L
> Wooden Stand



W36402
双头果汁鼎 (BPA FREE)
> Double Juice Dispenser 3.6LX2
> Wooden Stand



W36403
三头果汁鼎 (BPA FREE)
> Triple Juice Dispenser 3.6LX3
> Wooden Stand



36401-2
单头果汁鼎 (BPA FREE)
> Single Juice Dispenser 3.6L
> Wooden Stand

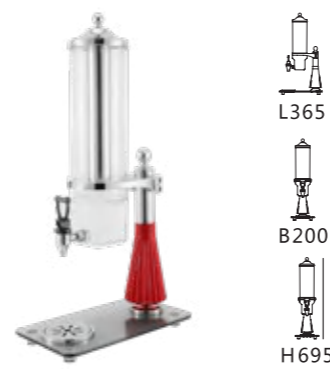

36402-2
双头果汁鼎 (BPA FREE)
> Double Juice Dispenser 3.6LX2
> Wooden Stand

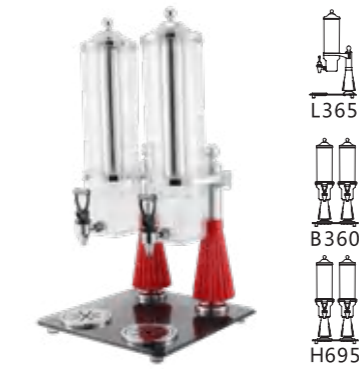

36403-2
三头果汁鼎 (BPA FREE)
> Triple Juice Dispenser 3.6LX3
> Wooden Stand



F10401-2
单头果汁鼎 / 带孔冰管 8L



> Single Juice Dispenser
> infusion 8L

EB10401
单头电热果汁鼎 8L



可选用 DB-180A 电热板
> Single Juice Dispenser
> Heating plate 180W 8L

36406
三头旋转果汁鼎



> Triple Juice Dispenser 3.6LX3

36306
三头旋转麦片器

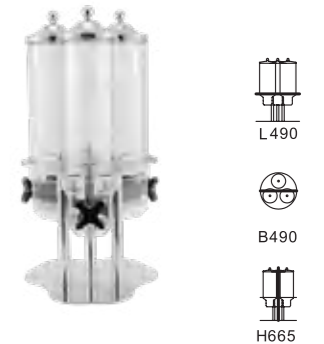

> Triple Cereal Dispenser 3.6LX3

麦片机系列

果汁鼎系列



Modeling design of Roman column
Elegant and luxurious

罗马柱造型设计
造型优雅、豪华大方

Rotary chassis can be purchased for more convenient use.

可选购旋转底盘，使用更方便。

Special drip trough design,
Easy to disassemble and clean.

特有的滴水槽设计，易拆装，
清洗更方便。

C12402 / C12402G

5升单联果汁鼎(镀金)(镀铬)

> Juice Dispenser
> 5L



L300
W243
H540

C12404 / C12404G

5升单联果汁鼎(镀金)(镀铬)

> Polygonal Juice Dispenser
> 5L



L300
W243
H540

JUICE DISPENSERS 果汁鼎系列

C12401 / C12401G

5升单联果汁鼎(镀金)(镀铬)

> Juice Dispenser
> 5L



L350
W243
H540

C12401-2 / C12401G-2

6升双联果汁鼎(镀金)(镀铬)

> Juice Dispenser
> 5LX2



L348
W556
H540

C12403 / C12403G

5升单联果汁鼎(镀金)(镀铬)

> Polygonal Juice Dispenser
> 6L



L348
W243
H540

C12403-2 / C12403G-2

5升双联果汁鼎(镀金)(镀铬)

> Juice Dispenser
> 6LX2



L348
W556
H540

S12401 / S12401G

5升单联果汁鼎(镀金)(镀铬)

> Polygonal Juice Dispenser
> 5L



L350
W243
H540

S12401-2 / S12401G-2

5升双联果汁鼎(镀金)(镀铬)

> Polygonal Juice Dispenser
> 5LX2



L348
W556
H540

B10402

全钢双连果汁鼎 /11L
> Juice Dispenser
> 2/11L



Particular tube design,
keep fresh lasting.

独有冰槽设计
连体设计，并带有独有冰槽设计，让饮品持久保鲜。



Drainage in the back, easy to following the cooling water out.
Convenient and useful, easy to use.

后背特有的排水孔设计
便于冰水排出，方便实用，操作简单。

10401-1

镀金单连果汁鼎 /8L
> Juice Dispenser
> 6L

**B10401**

全钢单连果汁鼎
> Polygonal Juice Dispenser
> 6L

**C10401-1**

镀金单连果汁鼎
> Juice Dispenser
> 6L

**C10401-2**

全钢单连果汁鼎
> Juice Dispenser
> 6L

**JUICE SERIES (系列)****10403-1**

镀金三连果汁鼎 8Lx3
> Polygonal Juice Dispenser
> 6Lx3

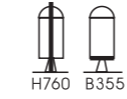
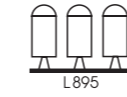
**10403-2**

全钢三连果汁鼎 8Lx3
> Polygonal Juice Dispenser
> 6Lx3

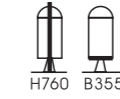
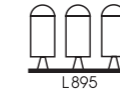
**2580G-9E**

果汁鼎

> Juice Dispenser
> 6L

**19401G**

果汁鼎

> Juice Dispenser
> 6L

**19401-10**

果汁鼎

> Juice Dispenser
> 10L

**10402-1**

镀金双连果汁鼎 6Lx2
> Polygonal Juice Dispenser
> 6Lx2

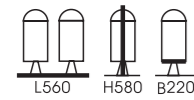
**10402-2**

全钢双连果汁鼎 6Lx2
> Polygonal Juice Dispenser
> 6Lx2

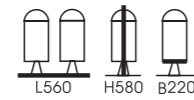
**J10401**

多角形果汁鼎 /11L
> Juice Dispenser
> 11L

**19401-15**

果汁鼎

> Juice Dispenser
> 15L

**19402**

全钢单连果汁鼎

> Polygonal Juice Dispenser
> 10L



JUICE SERIES (系列)

OTHER SERIES 其他类

W19401-5
木框果汁鼎

> Wooden frame Juice Dispenser
> 5L



W19401-6
木框果汁鼎

> Wooden frame Dispenser
> 6L



W19401-9
木框果汁鼎

> Wooden frame Juice Dispenser
> 9L



W19401-13
木框果汁鼎

> Wooden frame Juice Dispenser
> 13L



JUICE SERIES (系列)

OTHER SERIES 其他类

F19401-10
不锈钢底座果汁鼎

> Stainless steel base Juice Dispenser
> 10L



F19401-10B
不锈钢喷漆底座果汁鼎

> Stainless steel base Juice Dispenser
> 10L



F19401-15
不锈钢底座果汁鼎

> Stainless steel base Juice Dispenser
> 15L



F19401-15B
不锈钢喷漆底座果汁鼎

> Stainless steel base Juice Dispenser
> 15L



果汁鼎系列

果汁鼎系列

JUICE SERIES (系列)

OTHER SERIES 其他类

F19401H-10

不锈钢镂空底座果汁鼎

> Stainless steel hollow base stand Juice Dispenser > 10L



F19401H-10B

不锈钢镂空喷漆底座果汁鼎

> Stainless steel hollow base stand Juice Dispenser > 10L



F19401H-15

不锈钢镂空底座果汁鼎

> Stainless steel hollow base stand Juice Dispenser > 15L



F19401H-15B

不锈钢镂空喷漆底座果汁鼎

> Stainless steel hollow base stand Juice Dispenser > 15L



COFFEE DISPENSER SERIES 咖啡鼎系列

标配酒精炉 可选配电热板

OTHER SERIES 其他类

10501

镀金鼓形咖啡鼎 /8L

> Brass-plated Coffee dispenser > 8L

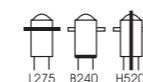

10701

镀金咖啡暖鼎 /7L

> Brass-plated Coffee dispenser > 7L

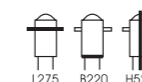

10801

镀金咖啡暖鼎 /10L

> Brass-plated Coffee dispenser > 10L

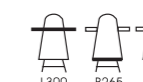

型号	额定功率	额定电压	额定频率	
10501	180W	220-240V~	50/60HZ	
10701	180W	220-240V~	50/60HZ	适用 10A 国际插头
10801	180W	220-240V~	50/60HZ	适用 DB-180A 专用电热板

10501G

全钢鼓形咖啡鼎 /8L

> Stainless Steel Coffee dispenser > 8L

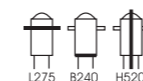

10701G

全钢咖啡暖鼎 /7L

> Stainless Steel Coffee dispenser > 7L

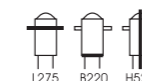

10801G

全钢咖啡暖鼎 /10L

> Stainless Steel Coffee dispenser > 10L

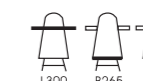

型号	额定功率	额定电压	额定频率	
10501G	180W	220-240V~	50/60HZ	
10701G	180W	220-240V~	50/60HZ	适用 10A 国际插头
10801G	180W	220-240V~	50/60HZ	适用 DB-180A 专用电热板

果汁鼎系列

果汁鼎系列

标配酒精炉 可选配电热板

10502

全钢鼓形咖啡鼎 /8L

> Stainless-Steel
Coffee dispenser
> 8L

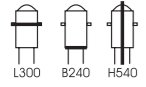

10802

全钢咖啡鼎 /10L

> Stainless-Steel
Coffee dispenser
> 10L

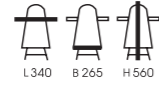

10702

全钢咖啡鼎 /7L

> Stainless-Steel
Coffee dispenser
> 7L

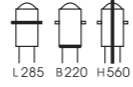

型号	额定功率	额定电压	额定频率	
10502	180W	220-240V~	50/60HZ	
10702	180W	220-240V~	50/60HZ	适用 10A 国际插头
10802	180W	220-240V~	50/60HZ	适用 DB-180A 专用电热板

10901L

全钢咖啡鼎 /8L

> Stainless-Steel
Coffee dispenser
> 8L

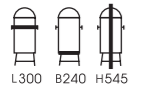

10902

全钢咖啡鼎 8L

> Stainless-Steel
Coffee dispenser
> 8L

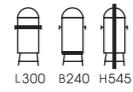

型号	额定功率	额定电压	额定频率	
10901L	180W	220-240V~	50/60HZ	适用 10A 国际插头
10902	180W	220-240V~	50/60HZ	适用 DB-180A 专用电热板

J10801

双层保温咖啡鼎 /12L

> Coffee um with
double wall
> 12L

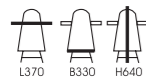

·具有四小时保温功能，
无需电和酒精加热。



J10801B

双层保温咖啡鼎 /12L

> Coffee um with
double wall
> 12L

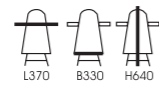

·具有四小时保温功能，
无需电和酒精加热。



Z10801

双层保温咖啡鼎 /12L

> Coffee um with
double wall
> 12L

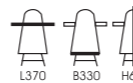

·具有四小时保温功能，
无需电和酒精加热。



COFFEE SERIES (系列)

10602

全钢咖啡鼎 (无加热功能) /8L

> Stainless-Steel
Coffee dispenser
(No heating function)
> 8L

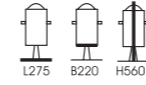

10601

镀金咖啡鼎 (无加热功能) /8L

> Brass-plated
Coffee dispenser
(No heating function)
> 8L

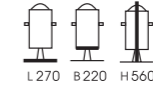

2581K-9E

咖啡鼎

> Stainless steel Coffee
Dispenser

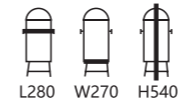

19901G

咖啡鼎

> Stainless steel Coffee
Dispenser

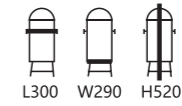

型号	容量	额定功率	额定电压	额定频率	
2581K-9E	7L	180W	220-240V~	50/60HZ	适用 DB-180A 专用电热板
19901G	7L	180W	220-240V~	50/60HZ	适用 10A 国际插头

10904

全钢牛奶暖鼎 /11L

> Stainless Steel
Coffee dispenser
> 11L

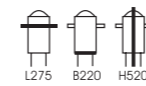

10903

全钢咖啡暖鼎 /10L

> Stainless Steel
Coffee dispenser
> 10L

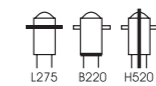

INDUCTION SERIES 电磁炉系列

EB-1200

电磁炉

> Buffet Induction

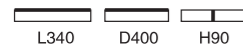

电磁炉开孔图

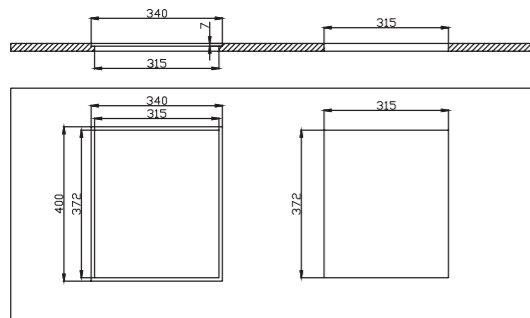

额定功率	额定电压	额定频率	
2100W	220-240V~	50/60HZ	适用 10A 国际插头

CF-1800

光波炉

> Infared Cooker



EB-450A

电磁炉

> Induction Cooker



EB-450B

800W 圆电磁炉

> Induction Cooker

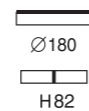

型号	额定功率	额定电压	额定频率	
CF-1800	1800W	220-240V~	50/60HZ	
EB-450A	450W	220-240V~	50/60HZ	适用 10A 国际插头
EB-450B	≤ 800W	220-240V~	50/60HZ	

CF-3600

双头光波炉

> Infared Cooker Double



额定功率	额定电压	额定频率	
3600W	220-240V~	50/60HZ	适用 10A 国际插头

EB-2400

双头电磁炉

> Buffet Induction Double

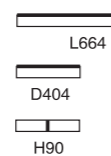

额定功率	额定电压	额定频率	
1800W	220-240V~	50/60HZ	适用 10A 国际插头

MEB-1200

电磁炉

> Buffet Induction
> 5L



HG1313

玻璃保温台

> Square glass warming tray

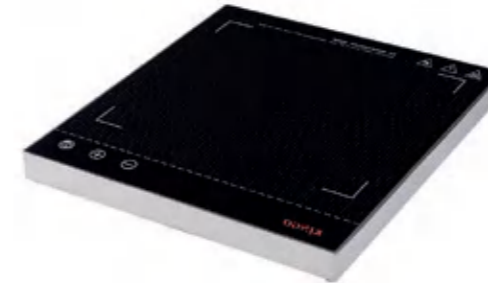

额定功率	额定电压	额定频率	
300W	220-240V~	50/60HZ	适用 10A 国际插头

HG2113

玻璃保温台

> Rectangle glass warming tray

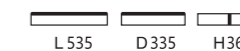

额定功率	额定电压	额定频率	
350W	220-240V~	50/60HZ	适用 10A 国际插头

HG0707

玻璃保温台

> Square glass warming tray



额定功率	额定电压	额定频率	
50W	220-240V~	50/60HZ	适用 10A 国际插头

HG1407

玻璃保温台

> Rectangle glass warming tray



额定功率	额定电压	额定频率	
1800W	220-240V~	50/60HZ	适用 10A 国际插头

WARMING TRAY SERIES 保温台系列

HG1313Q

嵌入式玻璃保温台
> Square glass warming tray



额定功率	额定电压	额定频率	
300W	220-240V~	50/60HZ	适用 10A 国际插头

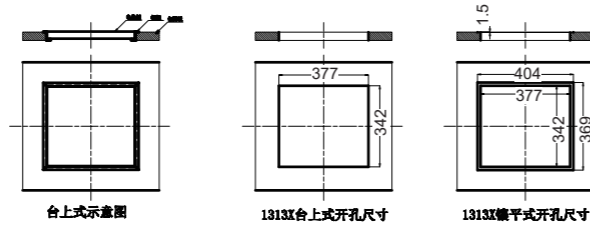

HG1901Q

嵌入式玻璃保温台
> Rectangle glass Built-in warming tray



额定功率	额定电压	额定频率	
1KW	220-240V~	50/60HZ	适用 10A 国际插头

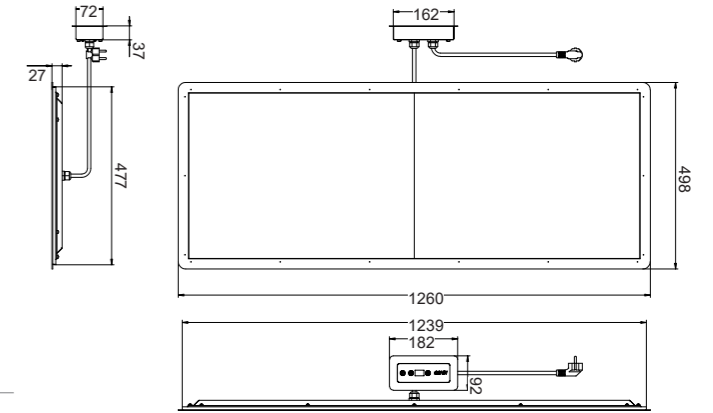

HG2113Q

嵌入式玻璃保温台
> Rectangle glass warming tray



额定功率	额定电压	额定频率	
350W	220-240V~	50/60HZ	适用 10A 国际插头

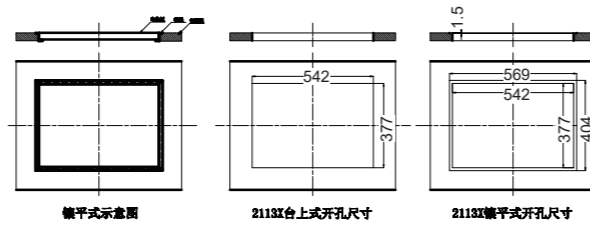

HG1901QC

嵌入式玻璃保温台
> Rectangle glass warming tray



额定功率	额定电压	额定频率	
1KW	220-240V~	50/60HZ	适用 10A 国际插头

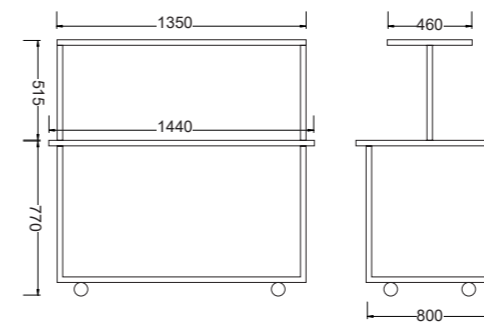

备注：不包括台面

MIRROR PLATE SERIES 镜盘镜台系列

Round Plate

无柄圆形镜面盘



型号	A (含柄)	H
880122	560	20
870120	515	20
860118	480	20

Round Plate/W.Handles

连柄圆形镜面盘



型号	A (无柄)	B	H
880122-1	670	560	38
870120-1	625	515	38
860118-1	590	480	38

Round Plate/W.Handles

叠柄圆形镜面盘



型号	A (无柄)	B	H
880122-2	635	560	65
870120-2	585	510	65
860118-2	530	480	65

Round Plate/W.Handles

叠柄圆形镜面盘



型号	A (无柄)	B	H
G880122-2	635	460	65
G870120-2	585	510	65
G860118-2	530	480	65

Oblong Tray

无柄方形镜面盘



型号	A (无柄)	B	H
880222	560	420	20
870220	520	370	20
860218	475	325	20

Oblong Tray/W.Handles

连柄方形镜面盘



型号	A (无柄)	B	H
880222-1	670	420	38
870220-1	630	370	38
860218-1	585	325	38

Oblong Tray/W.Handles

叠柄方形镜面盘



型号	A (无柄)	B	H
880222-2	655	420	65
870220-2	580	370	65
860218-2	540	325	65

Oblong Tray/W.Handles

叠柄方形镜面盘



型号	A (无柄)	B	H
G880222-2	655	420	65
G870220-2	580	370	65
G860218-2	540	325	65

Oval Plate

无柄椭圆形镜面盘



型号	A (无柄)	B	H
880322	575	445	20
870320	505	365	20
860318	460	320	20

Oval Plate/W.Handles

连柄椭圆形镜面盘



型号	A (无柄)	B	H
880322-1	665	445	38
870320-1	600	365	38
860318-1	550	320	38

Oval Plate/W.Handles

叠柄椭圆形镜面盘



型号	A (无柄)	B	H
880322-1	645	445	65
870320-1	560	365	65
860318-1	505	320	65

Oval Plate/W.Handles

叠柄椭圆形镜面盘



型号	A (无柄)	B	H
G880322-1	645	445	65
G870320-1	560	365	65
G860318-1	505	320	65

TRAY SERIES 镜盘镜台系列

G8530-1 / G8540-1

G8550-1

镀金高脚水果盘

> Compo With Brass Leg

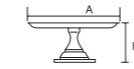

型号	A	H
G8530-1	305	175
G8540-1	405	185
G8550-1	505	195

G8530-2 / G8540-2

G8550-2

全钢高脚水果盘

> Compo With Stainless Steel Leg

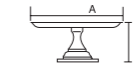

型号	A	H
G8530-2	305	175
G8540-2	405	185
G8550-2	505	195

S8804

镀金点心镜台

> Roll Top cover
> mirror plate
> gilt handle



S8805

全钢点心镜台

> Roll Top cover
> mirror plate
> gilt handle



S8806

镀金点心镜台

> KPL/D
> ALE Multiplex

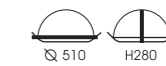

S8807

全钢点心镜台

> KPL/D
> ALE Multiplex

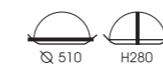

4020B

圆形有花镜台

> Round Mirror Prate/Rose



4122B

长方形有花镜台

> Oblong Mirror Prate/Rose



4220B

方形有花镜台

> Oblong Mirror Prate/Rose



4322B

椭圆形有花镜台

> Oblong Mirror Prate/Rose



4424B

六角形有花镜台

> Hxagon Mirror Prate/Rose

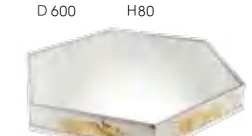

ARTICLES SERIES 用品系列

OTHER SERIES 其他类

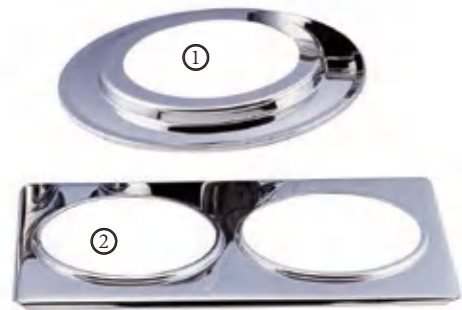

序号	型号	名称	描述	面板直径 (长)	内孔直径 (宽)
1	6606	圆形汤炉面板	Round Buffet Stand	380	220
2	6607	长方形汤炉面板	Oblong Buffet Stand	540	330

6001

方形搁盘
> Service Tong Holder



6002

扇形搁盘
> Service Tong Holder



6005

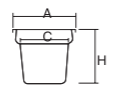

A	C	H	容量
250	220	150	4.6L



6004

酒精炉
> Lamp



1001

1L 双层冰桶
> Ice Bucket



ARTICLES SERIES 用品系列

OTHER SERIES 其他类

6003-1

汤更
> Deluxe Ladle



6003-2

食物夹
> Tong



6003-3

有孔炒更
> Slotted Spoon



6003-4

饭更
> Spoon



6012

圆食物盘 315*65
> Stainless Steam Table Pans
> 4L



6008

圆食物盘 380*65
> Stainless Steam Table Pans
> 6L



6009

圆双格食物盘 380*65
> Round insert Divided
> 6L



5035/5045

不锈钢沙律盘
> Stainless Steel Punch Bowl
> 5L



用品系列

用品系列

SOUP KETTLE SERIES 用品系列

OTHER SERIES 其他类

用品系列

OTHER SERIES 其他类

用品系列

D8001

600w 暖汤煲

> Soup Kettle
> 11L



容量	额定功率	额定电压	额定频率	
11L	600W	220-240V~	50/60HZ	适用 10A 国际插头

D8004

600w 暖汤煲

> Soup Kettle
> 11L



D8005

600w 暖汤煲

> Soup Kettle
> 11L



Q19010

600w 温度显示暖汤煲

> Soup Kettle
> 11L

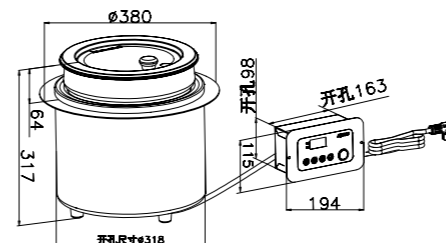

容量	额定功率	额定电压	额定频率	
10L	600W	220-240V~	50/60HZ	适用 10A 国际插头

D8002

600w 暖汤煲

> Soup Kettle
> 11L

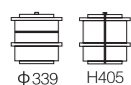

D9001-R

600w 暖汤煲

> Soup Kettle
> 11L

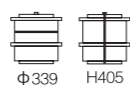

容量	额定功率	额定电压	额定频率	
10L	600W	220-240V~	50/60HZ	适用 10A 国际插头

D9001-Q

800w 嵌入式暖汤煲

> Soup Kettle
> 11L

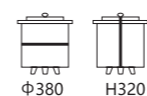

容量	额定功率	额定电压	额定频率	
11L	800W	220-240V~	50/60HZ	适用 10A 国际插头

D9001-A

800w 暖汤煲

> Soup Kettle
> 11L

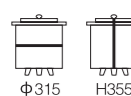

容量	额定功率	额定电压	额定频率	
11L	800W	220-240V~	50/60HZ	适用 10A 国际插头

嵌入式汤煲示意图



BUFFET STAND 自助餐搁架

Hex buffet stand 六角形搁架

序号	型号	L	W	H
1	S1136-1	415	360	240
	S1130-1	346	300	230
2	S1136-2	415	360	240
3	S1136-3	415	360	240
4	S1120-4	230	200	200
5	S1120-5	230	220	200
6	S1120-6	230	200	200

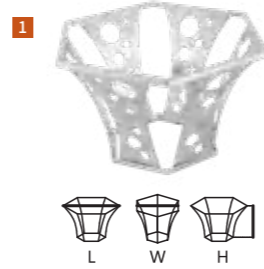

Square buffet stand 方形搁架

序号	型号	L	W	H
7	F1120-1	200	200	200
	F1125-2	250	250	250
	F1130-3	300	300	300

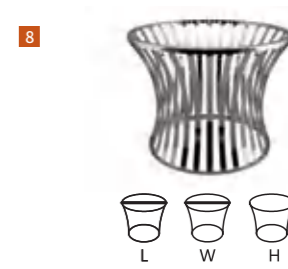
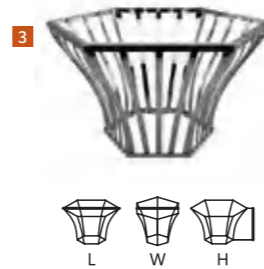

Round buffet stand 圆形搁架

序号	型号	L	W	H
8	Y1120-1	230	230	140
	Y1125-2	265	265	190
	Y1130-3	300	300	240



Hex buffet stand
六角形搁架

型号	L	W	H
G1054	1000	540	10
G8042	800	420	10
G6034	600	340	10
G4242	420	420	10

G6536

Fan-shaped glass 扇形玻璃



G6069

Glass plate /Hexagon 六角形玻璃



G6010

Round glass 圆形玻璃



3-TIER BUFFET CORNERS 3层自助餐角柱

BUFFET CORNER 自助餐角柱

OTHER SERIES 其他类

摆件系列

OTHER SERIES 其他类

摆件系列



3

2

1

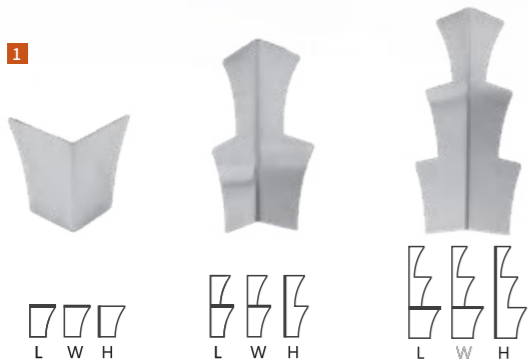

Buffet cross "choice" 自助餐角柱

序号	型号	L	W	H
1	C11-12	120	120	120
2	C11-24	120	120	240
3	C11-36	120	120	360

S4250

Three buffet tray rack
三层自助餐托盘架

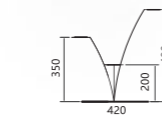

420×420×480

NG196

Step glass
阶梯玻璃



680×500×120

NG113

Step glass
阶梯玻璃



350×305×120

MANHATTAN/BUFFET STAND/SKYLINE 曼哈顿层架 - 天际线

OTHER SERIES 其他类

摆件系列



OTHER SERIES 其他类

摆件系列

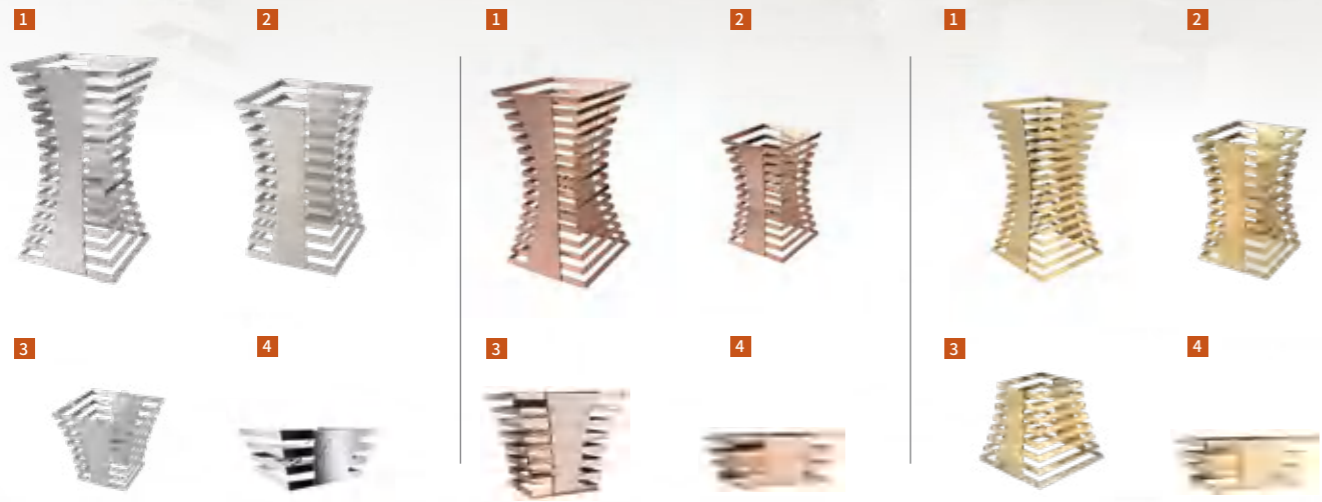

Manhattan/Buffer Stand 曼哈顿层架

序号	型号	L	W	H
1	M1120-1	256	256	470
	M1120-1G	256	256	470
	M1120-1RG	256	256	470
2	M1120-2	214	214	349
	M1120-2G	214	214	349
	M1120-2RG	214	214	349
3	M1120-3	256	256	227
	M1120-3G	256	256	227
	M1120-3RG	256	256	227
4	M1120-4	256	256	106
	M1120-4G	256	256	106
	M1120-4RG	256	256	106

Natural slate 天然板岩



序号	型号	L	W	H
A	S4242	420	420	10
B	S6042	600	420	10
C	S6960H	693	600	10
D	S6010C		Φ600	10

FOOD SHOWCASE 食物展示台

OTHER SERIES 其他类

摆件系列

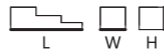

Trapezoidal combination Mirror
梯形组合镜台

序号	型号	L	W	H
1	A1101-1	435	200	155
	A1101-2	480	230	200
	A1101-3	525	260	245

Square Showcase
方形组合镜台

序号	型号	L	W	H
2	A1102-1	110	110	110
	A1102-2	140	140	140
	A1102-3	170	170	170
	A1102-4	200	200	200
	A1102-5	230	230	230
	A1102-6	260	260	260



COMBINATION BUFFET PLATE 自助餐组合敲打盘

OTHER SERIES 其他类

摆件系列

Square Plate
方形盘

序号	型号	L	W	H
1	800140C	250	150	35
	800141C	315	165	40
	800142C	315	255	45
2	800143C	515	315	50

Willow Plate
柳叶盘

序号	型号	L	W	H
2	880150C	470	260	40

Small-S shaped Plate
小S型盘

序号	型号	L	W	H
3	880160C	470	310	40

Large-S shaped Plate
大S型盘

序号	型号	L	W	H
4	880170C	470	450	40

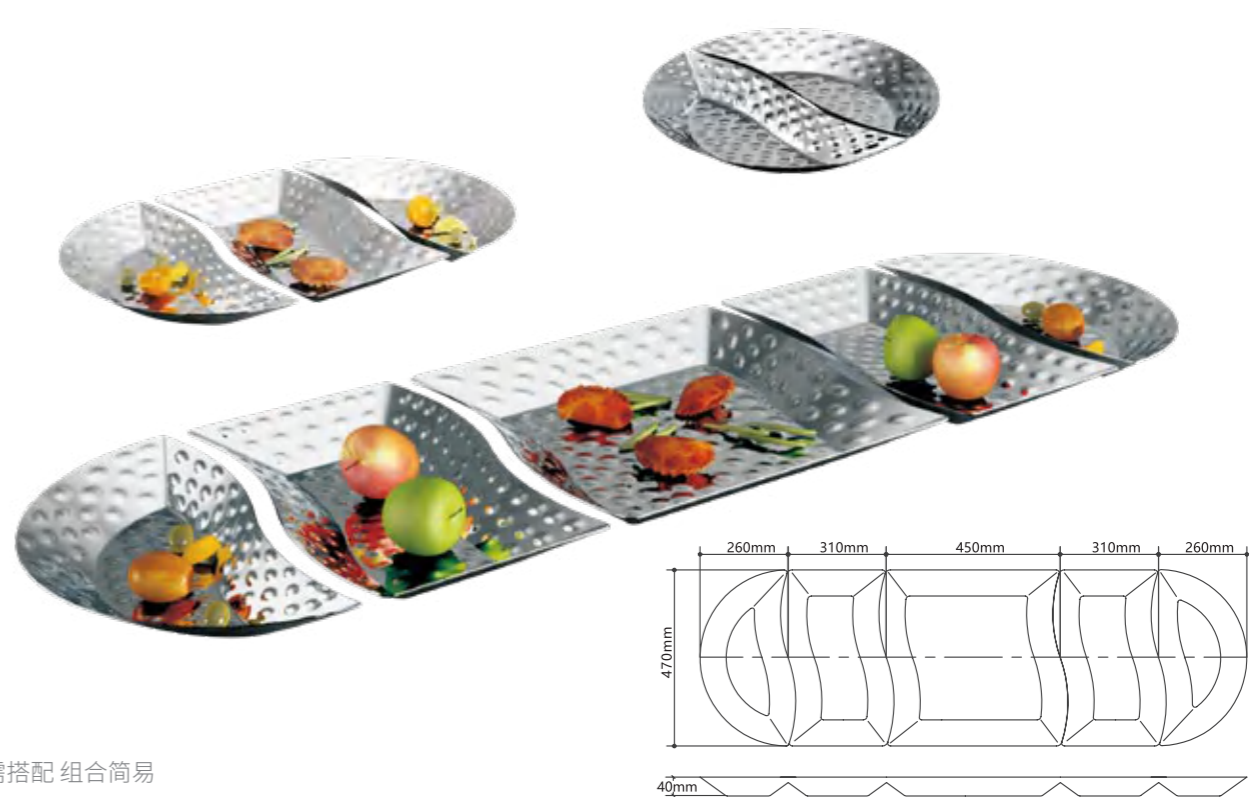
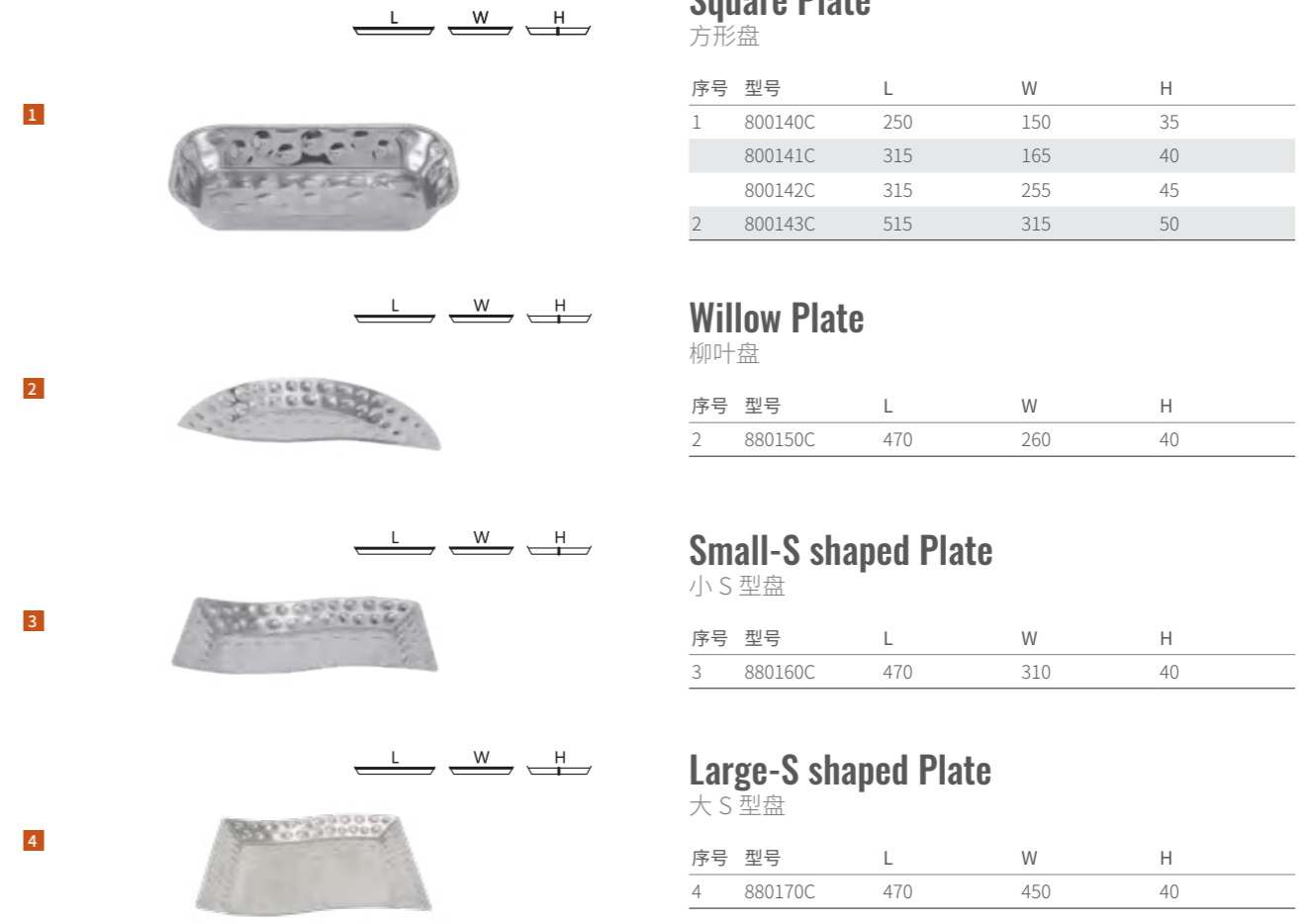

按需搭配 组合简易
Simple combination on demand

ART DE BUFFET 造型盘



2



Round Plate

圆型盘

序号	型号	D	H
1	A1107	250	85

Art Plate

艺术盘

序号	型号	L	W	H
2	A1108	185	185	80

Round Plate

圆型盘

序号	型号	D	H
3	A1109	276	55

Art Plate

艺术盘

序号	型号	L	W	H
4	A1110	205	205	56

Round Plate

沙律盘

序号	型号	W	H
5	A1112-1	390	240
	A1112-2	500	260

Round Bowl

圆型碗

序号	型号	W	H
6	A1113	180	80
	A1114	280	130

Round Bowl

圆型碗

序号	型号	W	H
7	A1115	180	80

1



3



4

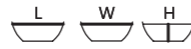

5



6



7



1

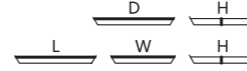

2

7

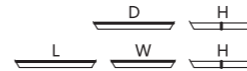

8

Round Plate

无柄圆形镜面盘

序号	型号	D	H
1	880122C	560	20
	870120C	515	20
	860118C	480	20

Round Plate/W.Handles

连柄圆形镜面盘 (镀金)

序号	型号	L	W	H
2	880122C-1	670	560	38
	870120C-1	625	515	38
	860118C-1	590	480	38

Round Plate/W.Handles

叠柄圆形镜面盘 (镀铬)

序号	型号	L	W	H
3	G880122C-2	635	560	65
	G870120C-2	585	515	65
	G860118C-2	530	480	65

Round Plate/W.Handles

叠柄圆形镜面盘 (镀金)

序号	型号	L	W	H
4	880122C-2	635	560	65
	870120C-2	585	515	65
	860118C-2	530	480	65

3



4

9



10

Oblong Tray

无柄方形镜面盘

序号	型号	L	W	H
5	880222C	560	420	20
	870220C	520	370	20
	860218C	475	325	20

Oblong Tray/W.Handles

连柄方形镜面盘 (镀金)

序号	型号	L	W	H
6	880222C-1	670	420	38
	870220C-1	630	370	38
	860218C-1	585	325	38

Oblong Tray/W.Handles

叠柄方形镜面盘 (镀铬)

序号	型号	L	W	H
7	G880222C-2	655	420	65
	G870220C-2	580	370	65
	G860218C-2	540	325	65

Oblong Tray/W.Handles

叠柄方形镜面盘 (镀金)

序号	型号	L	W	H
8	880222C-2	655	420	65
	870220C-2	580	370	65
	860218C-2	540	325	65

5



6

11



12

Oval Plate

无柄椭圆形镜面盘

序号	型号	L	W	H
9	880322C	575	445	20
	870320C	505	365	20
	860318C	460	320	20

Oval Plate/W.Handles

连柄椭圆形镜面盘 (镀金)

序号	型号	L	W	H
10	880322C-1	665	445	38
	870320C-1	600	365	38
	860318C-1	550	320	38

Oval Plate/W.Handles

叠柄椭圆形镜面盘 (镀铬)

序号	型号	L	W	H
11	G880322C-2	665	445	65
	G870320C-2	600	365	65
	G860318C-2	550	320	65

Oval Plate/W.Handles

叠柄椭圆形镜面盘 (镀金)

序号	型号	L	W	H
12	880322C-2	665	445	65
	870320C-2	600	365	65
	860318C-2	505	320	65

CERAMIC PLATE 陶瓷盘 (刚质瓷)

Stripe plate

条纹方盘

型号	L	W	H
NC8863-1	400	400	26
NC8863-2	460	460	28

Hexagonal plate

六角浅盘

型号	L	W	H
NC8864-1	440	400	26
NC8864-2	530	480	28

Turtle plate

海龟盘

型号	L	W	H
NC8872	118	88	16

Hippocampal plate

海马盘

型号	L	W	H
NC8871	190	110	15

Starfish plate

海星盘

型号	L	W	H
NC8870	178	170	28

Shell plate

贝壳盘

型号	L	W	H
NC8874	95	85	7.5



CERAMIC PLATE 陶瓷盘 (刚质瓷)

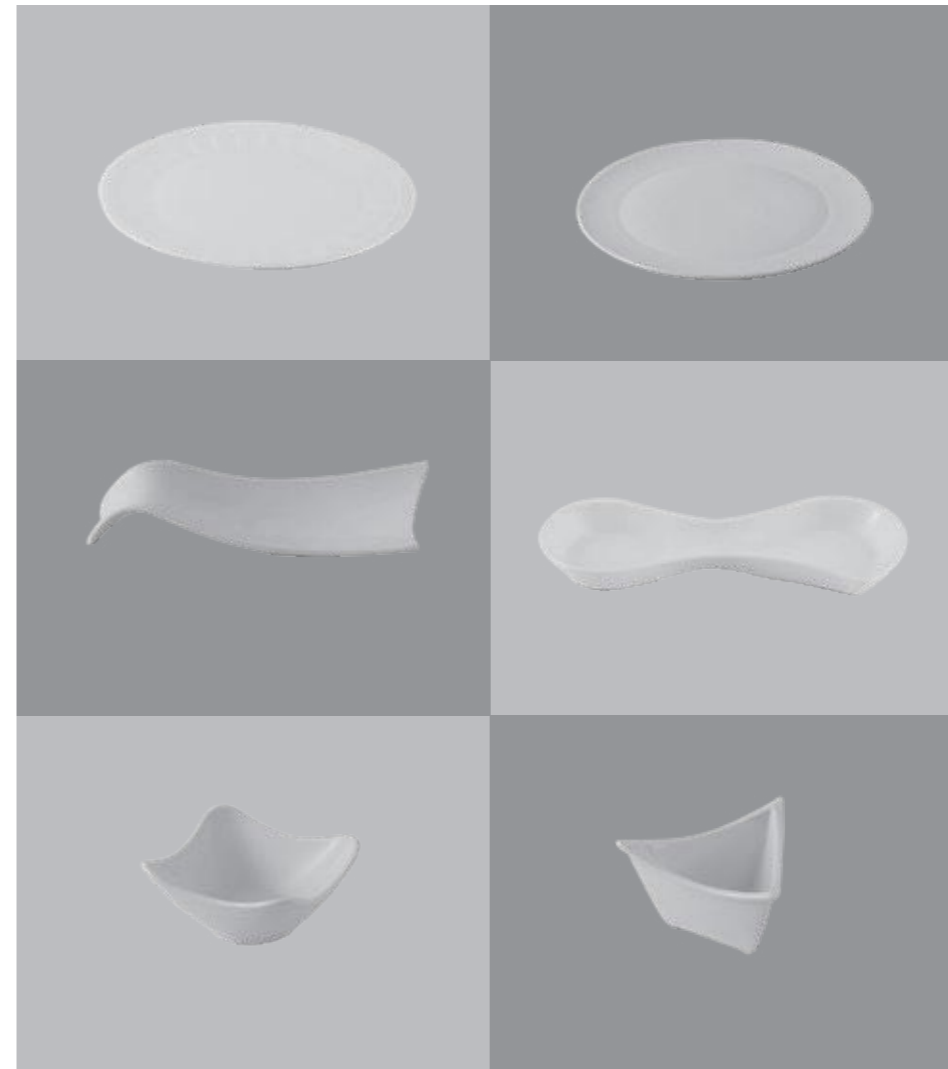

Jewel tracery plate

宝石纹平盘

型号	D	H
NC8865-1	Φ400	22
NC8865-2	Φ480	26

Burr plate

凸纹圆盘

型号	D	H
NC8866-1	Φ400	22
NC8866-2	Φ480	26

Ribbon plate

彩带盘

型号	L	W	H
NC8873	200	85	33

Peanut shell bowl

花生碗

型号	L	W	H
NC8869	167	70	19

Barley bucket bowl

麦斗碗

型号	L	W	H
NC8868	90	90	45

Tripod bowl

三足鼎碗

型号	L	W	H
NC8867	95	90	45



GLASS(GLASS MELTING) 玻璃 (熔制玻璃)

NF114

玻璃盘

型号	L	W	H
NC8867	445	445	8



SD2511

带电透明半翻盖宴会餐炉

NSG126

玻璃盘

型号	W	H
NSG126	Φ500	6



NG152

玻璃盘

型号	L	W	H
NG152	420	420	8



NA131

玻璃盘

型号	W	H
NA131	Φ400	6



NC137

玻璃盘

型号	L	W	H
NC137	350	350	6



NC104

玻璃盘

型号	L	W	H
NC104	390	390	6



NA113

玻璃盘

型号	W	H
NA131	Φ380	6



Oval Food Frame

椭圆形食物展示架

型号	L	W	H
A1104-1	420	130	470



锤印搁板
 ① G1 300×110×17.5
 ② G2 420×110×17.5
 ③ G3 300×110×17.5



Oval Food Frame

椭圆形食物展示架

型号	L	W	H
A1104-2	720	225	630



玻璃搁板
 ① B1 520×200×10
 ② B2 720×200×10
 ③ B3 580×200×10

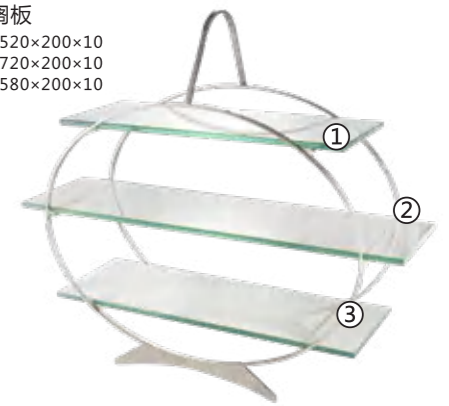

Champagne bucket

香槟桶

型号	L	W	H
A1105	300	200	525

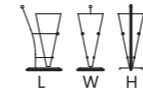

Showcase Tray

瓦形展示架



型号	L	W	H
A1106-1	200	200	40
A1106-2	300	300	40
A1106-3	400	400	60
A1106-4	500	500	60



A1103

不锈钢水果篮

> Fruit Basket

CINNABAR SERIES (系列)

W3008

摆件

> Pine ornaments



W3012

摆件

> Pine ornaments

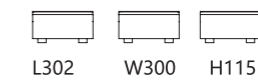

W3016

摆件

> Pine ornaments

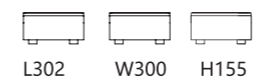

HEATING LAMPS/DOUBLE 双头多功能食物保温灯

KHL2518 HL2518 / HL2518-2

> L:635 W:460 H:690



KHL2518

额定功率	额定电压	额定频率	
500W	220-240V~	50/60HZ	适用 10A 国际插头

HL2418R

> L:610 W:410 H:680



额定功率	额定电压	额定频率	
500W	220-240V~	50/60HZ	适用 10A 国际插头

HL4020-2

> L:1020 W:500 H:730

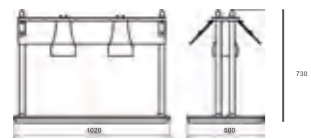

额定功率	额定电压	额定频率	
600W	220-240V~	50/60HZ	适用 10A 国际插头

HL4020

额定功率	额定电压	额定频率	
500W	220-240V~	50/60HZ	适用 10A 国际插头



HL4030/HL4030-2

> L:1020 W:500 H:730

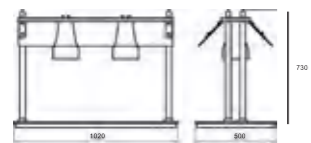

额定功率	额定电压	额定频率	
500W	220-240V~	50/60HZ	适用 10A 国际插头



HEATER PROOFER 移动保温柜



HP1500



L 815 W 545 H 1750

额定功率	额定电压	额定频率	
1500W	220-240V~	50/60HZ	适用 10A 国际插头

HP50/HP100



L 530 W 460 H 1520

额定功率	额定电压	额定频率	
1500W	220-240V~	50/60HZ	适用 10A 国际插头



CB-4
餐盒



PTA-1
餐盘



名称	L	W	H
餐盘	660mm	458mm	25mm

名称	L	W	H
餐盒	320mm	220mm	45mm



WD19001

单头暖碟机

> Single dish warmer

每头可容纳 70 至 100 个瓷盘，适用于 15-30 厘米直径的瓷盘，瓷盘承受力可有折半弹簧自行调节。



L550 W445 915



WD19002

双头暖碟机

> Dual-head dish warmer

每头可容纳 70 至 100 个瓷盘，适用于 15-30 厘米直径的瓷盘，瓷盘承受力可有折半弹簧自行调节。



L1000 W445 915



型号	额定功率	额定电压	额定频率	
WD19001	380W	220-240V~	50/60HZ	适用 10A 国际插头

型号	额定功率	额定电压	额定频率	
WD19002	380W	220-240V~	50/60HZ	适用 10A 国际插头

NEW STANDARD NEW DESIGN 新标准 新内涵 全新设计

STACKABLE AND NESTABLE
RECEPTACLES PATENT.

高强度、抗撞击、随意叠放、取用自如。

WE HAVE GOT THE PATENT OF DESIGN IN
CHINA, AMERICA, JAPAN.

已在中国、美国、日本获得专利。

New Anti-jamming GN Pans (Steam Table Pans)

A 款不锈钢份数盘 (食物盘)



Standard Anti-jamming GN Pans(Steam Table Pans)

B 款不锈钢份数盘 (食物盘)

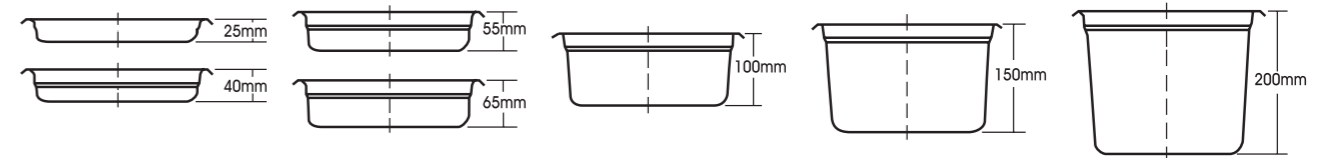
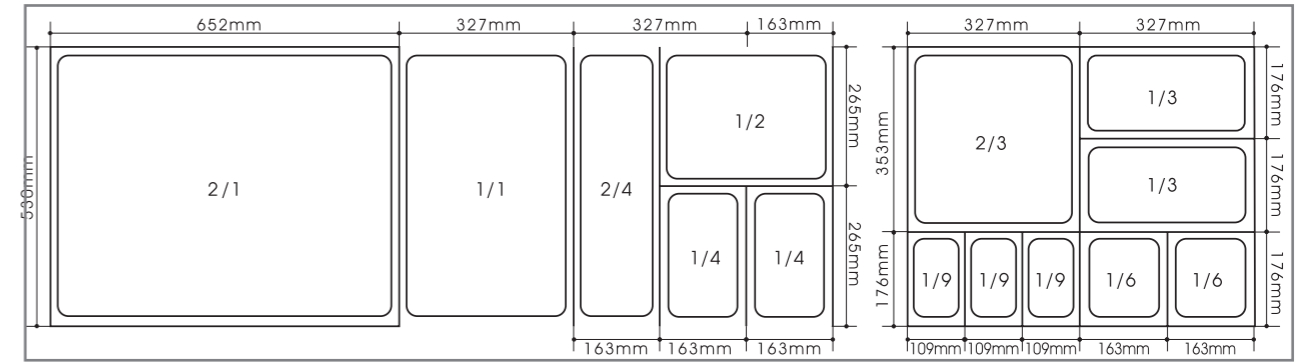

NEW ANTI-JAMMING GN PANS (STEAM TABLE PANS)

A 款不锈钢份数盘 (食物盘)

2/1 size pans

2/1 尺寸

> 530mmX652mm



型号 Item Code.	尺寸 Description	容量 Capacity(L)
A21025	2/1X1"(25mm)	7.0
A21040	2/1X1.5"(40mm)	13.0
A21065	2/1X2.5"(65mm)	18.0
A21100	2/1X4"(100mm)	28.3
A21150	2/1X6"(150mm)	43.0
A21200	2/1X8" (200mm)	57.3

1/1 size pans

1/1 尺寸

> 530mmX327mm



型号 Item Code.	尺寸 Description	容量 Capacity(L)
A11025	1/1X1" (25mm)	3.5
A11040	1/1X1.5" (40mm)	6.5
A11055	1/1X2.1"(55mm)	7.0
A11065	1/1X2.5"(65mm)	8.3
A11100	1/1X4" (100mm)	12.5
A11150	1/1X6" (150mm)	18.8
A11200	1/1X8" (200mm)	25.7

1/2 size pans

1/2 尺寸

> 265mmX327mm



型号 Item Code.	尺寸 Description	容量 Capacity(L)
A12025	1/2X1" (25mm)	1.6
A12040	1/2X1.5"(40mm)	3.0
A12065	1/2X2.5" (65mm)	3.8
A12100	1/2X4" (100mm)	6.0
A12150	1/2X6" (150mm)	8.9
A12200	1/2X8" (200mm)	11.6

2/4 size pans

2/4 尺寸

> 530mmX163mm



型号 Item Code.	尺寸 Description	容量 Capacity(L)
A24025	2/4X1" (25mm)	1.5
A24040	2/4X1.5" (40mm)	3.2
A24065	2/4X2.5" (65mm)	4.3
A24100	2/4X4" (100mm)	5.9
A24150	2/4X6" (150mm)	8.3

2/3 size pans

2/3 尺寸

> 353mmX327mm



型号 Item Code.	尺寸 Description	容量 Capacity(L)
A23025	2/3X1" (25mm)	1.4
A23040	2/3X1.5" (40mm)	3.5
A23065	2/3X2.5" (65mm)	5.1
A23100	2/3X4" (100mm)	7.9
A23150	2/3X6" (150mm)	12.2
A23200	2/3X8" (200mm)	16.5

1/3 size pans

1/3 尺寸

> 176mmX327mm



型号 Item Code.	尺寸 Description	容量 Capacity(L)
A13025	1/3X1" (25mm)	1.0
A13040	1/3X1.5" (40mm)	1.6
A13065	1/3X2.5" (65mm)	2.3
A13100	1/3X4" (100mm)	3.6
A13150	1/3X6" (150mm)	5.2
A13200	1/3X8" (200mm)	7.0

1/4 size pans

1/4 尺寸

> 265mmX163mm



型号 Item Code.	尺寸 Description	容量 Capacity(L)
A14025	1/4X1" (25mm)	0.6
A14040	1/4X1.5" (40mm)	1.1
A14065	1/4X2.5" (65mm)	1.6
A14100	1/4X4" (100mm)	2.5
A14150	1/4X6" (150mm)	3.7

1/6 size pans

1/6 尺寸

> 176mmX163mm



型号 Item Code.	尺寸 Description	容量 Capacity(L)
A16025	1/6X1" (25mm)	0.4
A16065	1/6X2.5" (65mm)	0.9
A16100	1/6X4" (100mm)	1.4
A16150	1/6X6" (150mm)	2.2

1/9 size pans

1/9 尺寸

> 176mmX109mm



型号 Item Code.	尺寸 Description	容量 Capacity(L)
A19025	1/9X1" (25mm)	0.2
A19065	1/9X2.5" (65mm)	0.6
A19100	1/9X4" (100mm)	0.9

Perforated pans

冲孔盘



型号 Item Code.	尺寸 Description
PA21025	2/1X1" Perforated
PA21040	2/1X1.5" Perforated
PA21065	2/1X2.5" Perforated
PA21100	2/1X4" Perforated
PA21150	2/1X6" Perforated
PA11025	1/1X1" Perforated
PA11040	1/1X1.5" Perforated
PA11065	1/1X2.5" Perforated
PA11100	1/1X4" Perforated
PA11150	1/1X6" Perforated
PA12025	1/2X1" Perforated
PA12040	1/2X1.5" Perforated
PA12065	1/2X2.5" Perforated
PA12100	1/2X4" Perforated
PA12150	1/2X6" Perforated
PA23025	2/3X1" Perforated
PA23040	2/3X1.5" Perforated
PA23065	2/3X2.5" Perforated
PA23100	2/3X4" Perforated
PA23150	2/3X6" Perforated

Standard Covers

份数盘盖



型号 Item Code.	尺寸 Description
21000	2/1 Lid
11000	1/1 Lid
12000	1/2 Lid
13000	1/3 Lid
14000	1/4 Lid
16000	1/6 Lid
19000	1/9 Lid
23000	2/3 Lid
24000	2/4 Lid
11000S	1/1 Lid 开口盖 W/Sloted
12000S	1/2 Lid 开口盖 W/Sloted
13000S	1/3 Lid 开口盖 W/Sloted
14000S	1/4 Lid 开口盖 W/Sloted
16000S	1/6 Lid 开口盖 W/Sloted
19000S	1/9 Lid 开口盖 W/Sloted

NEW ANTI-JAMMING GN PANS (STEAM TABLE PANS)

B 款不锈钢份数盘 (食物盘)

1/1 size pans

1/1 尺寸
> 530mmX327mm



型号 Item Code.	尺寸 Description	容量 Capacity(L)
11025	1/1X1" (25mm)	3.5
11040	1/1X1.5" (40mm)	6.5
11065	1/1X2.5"(65mm)	8.3
11100	1/1X4" (100mm)	12.5
11150	1/1X6" (150mm)	18.8
11200	1/1X8" (200mm)	25.7

1/2 size pans

1/2 尺寸
> 265mmX327mm



型号 Item Code.	尺寸 Description	容量 Capacity(L)
12025	1/2X1" (25mm)	1.6
12065	1/2X2.5" (65mm)	3.8
12100	1/2X4" (100mm)	6.0
12150	1/2X6" (150mm)	8.9
12200	1/2X8" (200mm)	11.6

2/4 size pans

2/4 尺寸
> 530mmX163mm



型号 Item Code.	尺寸 Description	容量 Capacity(L)
24065	2/4X2.5" (65mm)	4.3
24100	2/4X4" (100mm)	5.9
24150	2/4X6" (150mm)	8.3

2/3 size pans

2/3 尺寸
> 353mmX327mm



型号 Item Code.	尺寸 Description	容量 Capacity(L)
23025	2/3X1" (25mm)	1.4
23065	2/3X2.5" (65mm)	5.1
23100	2/3X4" (100mm)	7.9
23150	2/3X6" (150mm)	12.2
23200	2/3X8"(200mm)	16.5

1/3 size pans

1/3 尺寸
> 176mmX327mm



型号 Item Code.	尺寸 Description	容量 Capacity(L)
13065	1/3X2.5" (65mm)	2.3
13100	1/3X4" (100mm)	3.6
13150	1/3X6" (150mm)	5.2
13200	1/3X8" (200mm)	7.0

1/4 size pans

1/4 尺寸
> 265mmX163mm



型号 Item Code.	尺寸 Description	容量 Capacity(L)
14065	1/4X2.5" (65mm)	1.6
14100	1/4X4" (100mm)	2.5
14150	1/4X6" (150mm)	3.7

1/6 size pans

1/6 尺寸
> 176mmX163mm



型号 Item Code.	尺寸 Description	容量 Capacity(L)
16065	1/6X2.5" (65mm)	0.9
16100	1/6X4" (100mm)	1.4
16150	1/6X6" (150mm)	2.2

1/9 size pans

1/9 尺寸
> 176mmX109mm



型号 Item Code.	尺寸 Description	容量 Capacity(L)
19065	1/9X2.5" (65mm)	0.6
19100	1/9X4" (100mm)	0.9

Perforated pans

冲孔盘



	型号 Item Code.	尺寸 Description
1/1 尺寸 size pans 530mmX327mm	P11025	1/1X1" Perforated
	P11040	1/1X1.5" Perforated
	P11065	1/1X2.5" Perforated
	P11100	1/1X4" Perforated
1/2 尺寸 size pans 265mmX327mm	P11150	1/1X6" Perforated
	P12025	1/2X1" Perforated
	P12065	1/2X2.5" Perforated
	P12100	1/2X4" Perforated
2/3 尺寸 size pans 353mmX327mm	P12150	1/2X6" Perforated
	P23025	2/3X1" Perforated
	P23040	2/3X1.5" Perforated
	P23065	2/3X2.5" Perforated
	P23100	2/3X4" Perforated
	P23150	2/3X6" Perforated

Standard Covers

份数盘盖



型号 Item Code.	尺寸 Description
11000	1/1 Lid
12000	1/2 Lid
13000	1/3 Lid
14000	1/4 Lid
16000	1/6 Lid
19000	1/9 Lid
23000	2/3 Lid
24000	2/4 Lid
11000S	1/1 Lid 开口盖 W/Sloted
12000S	1/2 Lid 开口盖 W/Sloted
13000S	1/3 Lid 开口盖 W/Sloted
14000S	1/4 Lid 开口盖 W/Sloted
16000S	1/6 Lid 开口盖 W/Sloted
19000S	1/9 Lid 开口盖 W/Sloted



COLOR STEAM TABLE PAN SERIES (彩色份数盘系列)

11065R

1/1 红色食物盘
> 1/1 food insert with red color
> 0.8mm

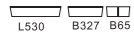

12065R

1/2 红色食物盘
> 1/2 food insert with red color
> 0.8mm



11065B

1/1 黑色食物盘
> 1/1 food insert with Black color
> 0.8mm



12065B

1/2 黑色食物盘 0.8mm
> 1/2 food insert with Black color
> 0.8mm



11065W

1/1 白色食物盘 0.8mm
> 1/1 food insert with White color
> 0.8mm



12065W

1/2 白色食物盘
> 1/2 food insert with White color
> 0.8mm



11025AP

1/1 涂层铝盘 (蛋形盘)
> 1/1 Coating Aluminum Pan

型号	尺寸	容量
11025AP	1/1X1" (25mm)	3.5



23025AP

2/3 涂层铝盘 (蛋形盘)
> 2/3 Coating Aluminum Pan

型号	尺寸	容量
20325AP	2/3X1" (25mm)	1.6



11025AF

1/1 涂层铝盘 (平盘)
> 1/1 Coating Aluminum Pan

型号	尺寸	容量
11025AF	1/1X1" (25mm)	3.5



23025AF

2/3 涂层铝盘 (平盘)
> 2/3 Coating Aluminum Pan

型号	尺寸	容量
20325AF	1/2X1" (25mm)	1.6



11025AW

1/1 涂层铝盘 (波形盘)
> 1/1 Coating Aluminum Pan

型号	尺寸	容量
11025AW	1/1X1" (25mm)	3.5



12025AW

2/3 涂层铝盘 (波形盘)
> 2/3 Coating Aluminum Pan

型号	尺寸	容量
20325AW	1/2X1" (25mm)	1.6



STEAM TABLE PAN SERIES (份数盘系列)

P11065

抛口份数盆

> GN pan 1/1*65mm*304*0.8mm with polished rim



P12065

抛口份数盆

> GN pan 1/2*65mm*304*0.8mm with polished rim



P13065

抛口份数盆

> GN pan 1/3*65mm*304*0.8mm with polished rim

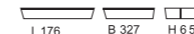

P23065

抛口份数盆

> GN pan 2/3*65mm*304*0.8mm with polished rim



P11065H

抛口份数盆

> GN pan 1/1*65mm*304*1.0mm with polished rim



P12065H

抛口份数盆

> GN pan 1/2*65mm*304*1.0mm with polished rim



P13065H

抛口份数盆

> GN pan 1/3*65mm*304*1.0mm with polished rim



P23065H

抛口份数盆

> GN pan 2/3*65mm*304*1.0mm with polished rim



P6008

抛口圆食物盘

> Round 38cm ss food pan >304*0.8mm with polished rim

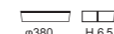

P6008H

抛口圆食物盘

> Round 38cm ss food pan >304*1.0mm with polished rim

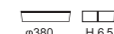

P6009

抛口圆双格食物盘

> Round 38cm ss food pan >304*0.8mm with polished rim

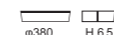

P6012

抛口圆食物盘

> Round 38cm ss food pan >304*0.8mm with polished rim

